

⚠ WARNING - FOR YOUR SAFETY - This product must be installed and serviced by authorized personnel, qualified in pool/spa heater installation. Improper installation and/or operation can create carbon monoxide gas and flue gases, which can cause serious injury, property damage, or death. For indoor installations, as an additional measure of safety, Zodiac Pool Systems, Inc. strongly recommends installation of suitable Carbon Monoxide detectors in the vicinity of this appliance and in any adjacent occupied spaces. Improper installation and/or operation will void the warranty.

Installation and Operation Manual

Jandy® LXi™ Gas-Fired Pool and Spa Heater

Model Jandy LXi Natural Gas and LP

This product is manufactured under the following
United States Patent: 5,163,508; additional patents pending.
And under the Canadian Patent: 2,076,188.



⚠ WARNING

If these instructions are not followed exactly, a fire or explosion may result, causing property damage, personal injury, or death.

Do not store or use gasoline or other flammable vapors and liquids in the vicinity of this or any other appliance.

WHAT TO DO IF YOU SMELL GAS

- Do not try to light any appliance.
- Do not touch any electrical switch; do not use any phone in your building.
- Immediately call your gas supplier from a neighbor's phone. Follow the gas supplier's instructions.
- If you cannot reach your gas supplier, call the fire department.

Installation and service must be performed by a qualified installer, service agency or the gas supplier.

Table of Contents

Section 1. General Information 5	Section 4. Gas Connections 16
1.1 Introduction.....5	4.1 Gas Supply and Piping.....16
1.2 Consumer Information and Safety.....5	4.2 Manifold Pressure17
1.2.1 Spa/Hot Tub Safety Rules.....5	4.3 Special Precautions for LP Gas17
1.2.2 Swimming Pool Energy Saving Tips6	
1.3 Warranty.....6	Section 5. Water Connections 18
1.4 Codes and Standards.....6	5.1 Water Piping.....18
1.5 Technical Assistance7	5.2 Check Valve Installation18
1.6 Materials Installer Must Provide7	5.3 Automatic Flow Control Valve18
1.6.1 Materials for All Applications7	5.4 Reversible Water Connections18
1.6.2 Materials for Special Applications.....7	5.5 Connections at Heater.....20
1.7 Specifications7	5.6 Pressure Relief Valve22
1.7.1 General Specifications7	5.7 Auxiliary Components, Chlorinators, Ozone Generators, and Sanitizing Chemicals.....23
1.7.2 Dimensions8	
 Section 2. Installation Instructions 9	 Section 6. Electrical..... 23
2.1 Introduction.....9	6.1 General Information.....23
2.2 Field Assembly9	6.2 Main Power23
2.3 Location Requirements9	6.2.1 Converting the Heater for a 120V Power Source25
2.3.1 Introduction9	6.3 Bonding25
2.3.2 Clearances.....9	6.4 Optional Pump Connection (Maintain Temp Feature)26
2.3.3 Flooring10	6.5 Optional Remote Controls26
2.3.4 Outdoor Installation.....10	6.5.1 Connection to a Remote Pool-Off-Spa Selector (3-Wire Connection).....27
2.3.5 Indoor and Outdoor Shelter Installations11	6.5.1.1 Install the Remote Pool-Off- Spa Selector27
2.3.5.1 Converting the Grill to a Vent Collar12	6.5.1.2 Configure the Control Panel27
 Section 3. Venting..... 12	6.5.2 Connection to an AquaLink RS Control System or Remote TSTAT (2-Wire Connection).....27
3.1 Combustion Air Supply12	6.5.2.1 Install the Remote TSTAT27
3.2 Exhaust Venting13	6.5.2.2 Configure the Control Panel28
3.3 Vent Pipe Sizing and General Installation14	6.5.2.3 Remote Operation28
3.3.1 Outdoor Installations.....14	6.5.3 Connection to a Secondary User Interface30
3.3.2 Indoor and Outdoor Shelter Installations14	
3.3.3 Inspection and Replacement of Existing Vent System with New Components15	

Table of Contents (Continued)

Section 7. Operating Instructions	30	Section 10. Professional Maintenance and Service.....	43
7.1 Normal Operation	30	10.1 General Information.....	43
7.2 Start-Up	30	10.2 “Premix” Forced-Draft Combustion System	43
7.3 Operating the Controller	31	10.3 Heater Components and Their Operation.....	43
7.3.1 Off Mode	32	10.4 Special Service Issues - Premix Combustion System	44
7.3.2 Pool Mode - (Normal Heat).....	32	10.4.1 System Operation.....	44
7.3.3 Pool Mode - (Optional Maintain Heat)	32	10.4.2 Field Service and Adjustment	44
7.3.4 Spa Mode - (Normal Heat).....	32	10.4.3 Burner Throat Pressure Adjustment	45
7.3.5 Spa Mode - (Optional Maintain Heat)	32	10.5 Electrical Troubleshooting	45
7.4 User Setup Options	32	10.5.1 Electrical Power Supply	45
7.4.1 Language Setup.....	32	10.5.2 Controller	46
7.4.2 Temperature Scale Setup	33	10.5.3 Control Circuit Troubleshooting ..	46
7.4.3 Spa Timer Setup	33	10.5.3.1 Transformer	46
7.4.4 Display Light Setup	33	10.5.3.2 Fuse	46
7.5 Set Point Lockout	33	10.5.3.3 Water Pressure Switch	46
7.6 Lighting and Shutdown Procedures	33	10.5.3.4 Fusible Link	47
7.6.1 Lighting the Heater.....	35	10.5.3.5 Temperature Limit Switches Circuit	47
7.6.2 Shutdown	35	10.5.3.6 Blower Pressure Switch Circuit	47
7.7 Adjusting the Water Pressure Switch	35	10.5.3.7 Gas Valve Voltage	48
7.8 Temperature Rise	36	10.5.3.8 Igniter/Ignition Control Circuit	48
7.9 Burner Throat Pressure Adjustment	37	11.2 Parts List	52
Section 8. Maintenance	37	Section 11. Replacement Parts	52
8.1 Water Chemistry	37	11.1 Ordering Information	52
8.2 Seasonal Care.....	38	11.3 General Exploded View	54
8.2.1 Spring and Fall Operation	38	11.4 Detailed Exploded View	55
8.2.2 Winterizing	38	11.5 Exploded View of Heat Exchanger, Bronze	56
8.2.3 Spring Start-up.....	38		
8.3 Inspection and Service	38		
8.3.1 Owner Inspection	39		
8.3.2 Professional Inspection.....	39		
Section 9. Troubleshooting	40		
9.1 General Heater Troubleshooting	40		
9.2 Service Codes	40		
9.3 Ignition Control LED Service Codes.....	40		

Section 1. General Information

1.1 Introduction

This manual provides installation and operation instructions for the Jandy LXi™ pool and spa heaters. Read these installation and operation instructions completely before proceeding with the installation. Consult the Jandy® factory, or local factory representative, with any questions regarding this equipment.

Certain sections of this manual are specific to either United States or Canadian installations, and are labeled as such.

The LXi heater gets electrical power from an external 120VAC or 240VAC source and provides a dual electronic thermostat control system for pool/spa combinations or preheat convenience.

The LXi heater is specifically designed for heating fresh water swimming pools and spas, and with proper installation and care, they will provide years of reliable service. Do not use the heater to maintain pool or spa water temperature below 70°F. Do not use it as a heating boiler or general service water heater or to heat salt water. Consult your dealer for the appropriate Jandy products for these applications.

In the LXi heater, operation is achieved through use of a special “premix” combustion system. The operation of this type of system is affected by fuel gas properties. As noted in the troubleshooting and maintenance sections of this manual, adjustments may be necessary if the local gas supply is of especially high or low heat content.

1.2 Consumer Information and Safety

The LXi heater is designed and manufactured to provide many years of safe and reliable service when installed, operated, and maintained according to the information in this manual and the installation codes referred to in later sections. Throughout the manual safety warnings are identified by the “▲” symbol and safety cautions are surrounded by a border. Be sure to read and comply with all of the warnings and cautions.

1.2.1 Spa/Hot Tub Safety Rules

▲ WARNING

The following “Safety Rules for Hot Tubs,” recommended by the U.S. Consumer Product Safety Commission, should be observed when using the spa.

▲ AVERTISSEMENT

Les Règlements suivants pour Cuves Thermales, tel que recommandés par la Commission U.S. de Sécurité des Produits pour les Consommateurs, devraient être respectés lors de l'utilisation du spa.

▲ WARNING

The U.S. Consumer Product Safety Commission warns that elevated water temperature can be hazardous. Consult heater operation and installation instructions for water temperature guidelines before setting temperature.

▲ AVERTISSEMENT

La U.S. Consumer Product Safety Commission indique que des températures de l'eau élevées peuvent être dangereuses. Voir la notice d'installation et de fonctionnement pour le réglage de la température.

1. Spa or hot tub water temperature should never exceed 104°F (40°C). One hundred degrees Fahrenheit (100°F [38°C]) is considered safe for a healthy adult. Special caution is recommended for young children.
2. The drinking of alcoholic beverages before or during spa or hot tub use can cause drowsiness which could lead to unconsciousness, and subsequently result in drowning.
3. **Pregnant women take note!** Soaking in water above 102°F (38.5°C) can cause fetal damage during the first three (3) months of pregnancy (which could result in the birth of a brain-damaged or deformed child). If pregnant women are going to use a spa or hot tub, they should make sure the water temperature is below 100°F (38°C) maximum.
4. The water temperature should always be checked with an accurate thermometer before entering a spa or hot tub. Temperature controls may vary by as much as 1F° (1C°).
5. Persons with a medical history of heart disease, diabetes, circulatory or blood pressure problems should consult their physician before using a hot tub or spa.
6. Persons taking any medication which induces drowsiness (e.g., tranquilizers, antihistamines, or anticoagulants) should not use spas or hot tubs.
7. Prolonged immersion in hot water can induce hyperthermia.

Hyperthermia occurs when the internal body temperature reaches a level several degrees above the normal body temperature of 98.6°F (37°C). Symptoms include dizziness, fainting, drowsiness, lethargy, and an increase in the internal body temperature. The effects of hyperthermia include:

- Lack of awareness of impending hazard
- Failure to perceive heat
- Failure to recognize need to leave spa
- Physical inability to leave spa
- Fetal damage in pregnant women
- Unconsciousness resulting in a danger of drowning

1.2.2 Swimming Pool Energy Saving Tips

Zodiac Pool Systems, Inc., offers the following recommendations to help conserve fuel and minimize the cost of operating your pool heater without sacrificing comfort.

1. The American Red Cross recommends a maximum water temperature of 78°F (25°C). Use an accurate pool thermometer. A difference of 4F° (2°C), between 78°F and 82°F (26°C and 28°C), will use as much as 40% more gas.
2. Carefully monitor the water temperature of your pool in the summertime. You can reduce heater usage due to warmer air temperatures.
3. Find the proper setting on the pool heater temperature control and use the Set Point Lockout feature to discourage further adjustments.
4. Set the pump time clock to start the pump no earlier than 6:00 AM during the pool heating season. This is the time when nightly heat loss balances.
5. If the pool is only going to be used on weekends, reduce the heater temperature control setting by 8 or 10 degrees during the week. Reset it to the 78°F (25°C) level a day or so before you plan to use the pool.
6. During the winter or when on vacation for longer than a week, shut down the heater by following the shutdown instructions found on the inside of the heater.
7. Where possible, shelter the pool from prevailing winds with well-trimmed hedges or other landscaping, cabanas, or fencing.
8. Always use a pool cover when practical. Besides providing a valuable safety feature, a pool cover will reduce heat loss, conserve chemicals, and reduce the load on filter systems.

1.3 Warranty

The LXi heater is sold with a limited factory warranty. Details are specified on the back cover of this manual.

Make all warranty claims to an authorized Jandy representative or directly to the factory. Claims must include the heater serial number and model (this information can be found on the rating plate), installation date, and name of the installer. Shipping costs are not included in the warranty coverage.

The warranty does NOT cover damage caused by improper assembly, installation, operation or field modification. Also, damage to the heat exchanger by corrosive water is NOT covered by the warranty. See *Section 8.1, Water Chemistry*, for maintaining proper pool water chemistry.

NOTE Keep this manual in a safe place for future reference when inspecting or servicing the heater.

1.4 Codes and Standards

The LXi pool and spa heaters are design-certified by CSA (Canadian Standards Association) as complying with the latest edition of the *Standard for Gas Fired Pool Heaters*, ANSI Z21.56 in the USA and CAN-4.7 in Canada.

All Jandy heaters must be installed in accordance with the local building and installation codes as per the utility or authorities having jurisdiction. All local codes take precedence over national codes.

In the absence of local codes, refer to the latest edition of the following national codes for installation:

1. In the United States, the *National Fuel Gas Code*, NFPA 54/ANSI Z223.1. Pay particular attention to the chapter addressing *Venting of Equipment*.
2. In Canada, the *Natural Gas and Propane Installation Code*, CAN/CSA-B149.1.

The LXi pool and spa heaters meet or exceed the requirements of energy conservation regulations, such as those in California, Hawaii, New York, Oregon and other states that require that a pool heater have intermittent ignition. In addition, the natural gas models of this heater comply with both the California South Coast Air Quality Management District's (SCAQMD) Rule 1146.2 and the Title 30, Texas Administrative Code, Chapter 117, Section 117.465 for Nitrogen Oxide (NOx) emissions.

Any changes to the heater, gas controls, gas orifices, wiring, draft diverter, or improper installation may void the warranty. If change is required to any of the above, consult the factory.

1.5 Technical Assistance

Consult Zodiac Pool Systems, Inc. or your local Jandy distributor with any questions or problems involving the specifications, installation, and operation of your Jandy equipment. An experienced member of the technical support staff is ready to assist you in assuring the proper performance and application of Jandy products. For technical support, call the Technical Service Department at 800.822.7933.

1.6 Materials Installer Must Provide

1.6.1 Materials for All Applications

The following items are needed and are to be supplied by the installer for all LXi heater installations:

1. The correct size gas pipe to supply gas from the meter to the heater. See *Section 4.1*.
2. A manually operated gas valve to be installed in the gas line outside of the heater jacket.
3. A suitable gas union joint to connect the heater to the gas line outside of the heater.
4. Plumbing items needed to provide a sediment trap (drip leg) in the gas line between the manual gas valve and the heater. See *Section 4.1*.
5. A 120V AC or 240V AC power supply. A junction box is not needed at the heater; connections are made inside of the heater jacket.

1.6.2 Materials for Special Applications

In addition to the items listed above, the following items are needed for special applications:

1. A factory authorized vent collar and any vent pipe needed for indoor installations in the USA and outdoor shelter installations in Canada. (See *Section 3.3.2*). A vertical vent collar comes with the unit. A side vent kit is available from your Jandy distributor.
2. Primer and cement suitable for cementing CPVC pipe to PVC pipe and an appropriate coupling for connecting the factory supplied CPVC pipe nipples to PVC pool plumbing.

3. A noncombustible platform for installation on combustible surfaces. (See *Section 2.3.3*.) Non-combustible bases are available from your Jandy distributor.

1.7 Specifications

1.7.1 General Specifications

1. Installation Location:
 Certified for use:
 In the USA:
 Natural Gas: Indoor and Outdoor
 LP: Indoor and Outdoor
 In Canada:
 Natural Gas : Outdoor and Outdoor Shelter
 LP: Outdoor and Outdoor Shelter
2. Minimum Clearance From Combustible Material:
 See Table 2 in *Section 2.3.2*.
3. *Gas Pipe/Heater Gas Valve Connection:
 Natural Gas: 3/4" NPT
 LP: 3/4" NPT
*For diameter of gas line from meter to heater, see Table 5 in *Section 4.1*.
4. Supply Gas Type:
 Certified for use with:
 Natural Gas and LP
5. Inlet Gas Supply Pressure:

	Minimum	Maximum
Natural Gas:	5.0 "WC	10.5 "WC
LP:	11.0 "WC	14.0 "WC
6. Manifold Gas Pressure:
 Natural Gas: 2.5 "WC
 LP: 9.0 "WC
7. Air Plenum Pressure: 1.5 "WC
8. Burner Throat Pressure: 1.0 "WC
9. Water Pipe/Heater Connection:
 *2" Unthreaded PVC or CPVC
*Other size pipes may be used. See *Section 5.5* for details
10. Water Flow Rate:
 Maximum: 125 gpm (475 lpm)
 Minimum: 30 gpm (110 lpm)
11. Working Water Pressure:
 Maximum: 75 psi
12. Exhaust Vent Connection Size (Category I):
 Model:

250	6" Diameter
300	7" Diameter
400	8" Diameter

- 13. Electrical Supply:
Either 120 Volts AC or 240 Volts AC.
- 14. Modification of Heater for High Altitude:
LXi heaters are normally shipped from the factory in the low altitude (sea level) operational configuration. Table 1 defines the altitude designations as described by the *Standard for Gas Fired Pool Heaters*, ANSI Z21.56 in the United States and *Gas-Fired Appliances For Use At High Altitudes*, CAN1-2.17 in Canada. When an LXi heater is to be installed in a high altitude application, the burner throat pressure will need to be adjusted to achieve 1.0"WC. See *Section 10.4.3* for instructions on how to do this.

Table 1. Altitude Designations For The LXi Heater

NATURAL GAS		
ALTITUDE DESIGNATION	UNITED STATES	CANADA
LOW ALTITUDE	0-4500 FT	0-4500 FT (0-1370 M)
HIGH ALTITUDE	4501-10,000 FT	NOT APPLICABLE
LP		
LOW ALTITUDE	0-4500 FT	0-4500 FT (0-1370 M)
HIGH ALTITUDE	4501-10,000 FT	NOT APPLICABLE

1.7.2 Dimensions

See Figure 1 for a diagram showing the heater's exterior dimensions and dimensions to critical connections on the heater.

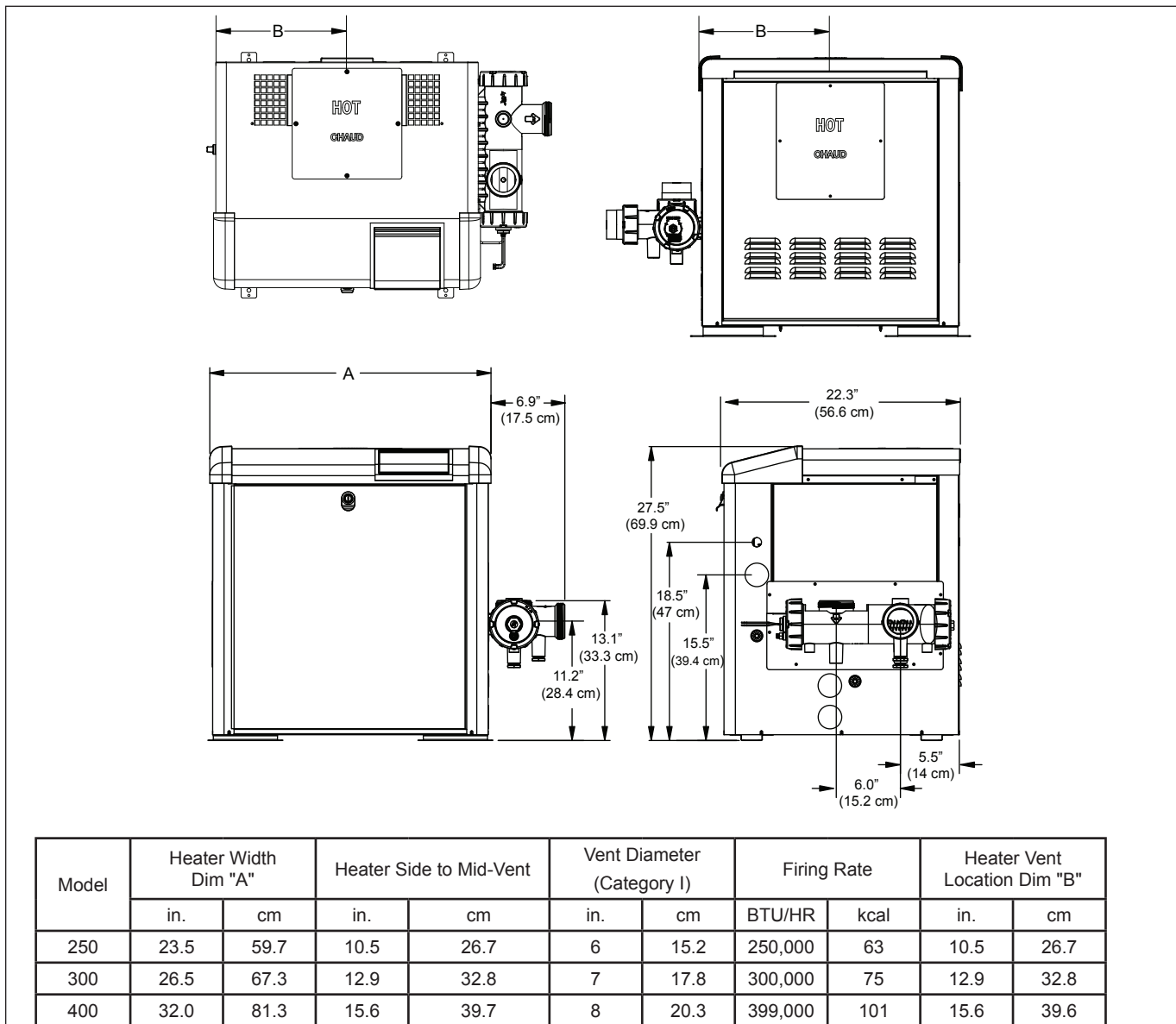

Figure 1. General Configuration

Section 2. Installation Instructions

2.1 Introduction

WARNING

Improper installation or maintenance can cause nausea or asphyxiation from carbon monoxide in flue gases which could result in severe injury, or death. For indoor installations, as an additional measure of safety, Zodiac Pool Systems, Inc. strongly recommends installation of suitable Carbon Monoxide detectors in the vicinity of this appliance and in any adjacent occupied spaces.

AVERTISSEMENT

Une installation ou un entretien inadéquat peut causer la nausée ou l'asphyxie en raison du monoxyde de carbone présent dans les gaz de combustion et même entraîner des blessures graves ou la mort. Pour les installations intérieures, comme mesure de sécurité additionnelle, Zodiac Pool Systems, Inc. recommande fortement l'installation de détecteurs de monoxyde de carbone près de cet appareil ainsi que dans les espaces adjacents occupés.

Install the LXi heater and vent collar in accordance with the procedures in this manual, local codes and ordinances, and in accordance with the latest edition of the appropriate national code. See *Section 1.4, Codes and Standards*.

All gas-fired products require correct installation to assure safe operation. The requirements for pool heaters include the following:

1. Field assembly (if required)
2. Appropriate site location (clearances) and flooring
3. Sufficient combustion and ventilation air
4. Properly sized gas meter and piping
5. Proper electrical wiring (if required)
6. Adequate water flow

This manual provides the information needed to meet these requirements. Review all application and installation procedures completely before continuing the installation.

2.2 Field Assembly

The LXi heater can be installed in a variety of ways, some of them requiring preparation or assembly in the field. The heater is shipped from the factory with an exhaust vent configured for an outdoor installation. The LXi heater is also design certified for “Indoor” installations in the United States and “Outdoor Shelter” installations in Canada when equipped with a vent collar and the appropriately sized exhaust vent.

Check the rating plate on the heater or the Parts List (*Section 11.2*) in this manual for the correct Jandy

vent collar part number. For specific installation information see *Section 2.3.5, Indoor and Outdoor Shelter Installations*.

Water connections are provided on the right side of the heater but can be changed to the left side by reversal of the heat exchanger. It is best to handle these preparations before the heater is installed in its final location. See *Section 5.4, Reversible Water Connections*, in this manual for instructions.

2.3 Location Requirements

2.3.1 Introduction

CAUTION

When pool equipment is located below the pool surface, a leak from any component can cause large scale water loss or flooding. Zodiac Pool Systems, Inc., cannot be responsible for such water loss or flooding or resulting damage.

ATTENTION

Lorsque l'équipement d'une piscine est situé sous la surface de l'eau, une fuite provenant de n'importe quel élément peut causer une perte d'eau importante ou une inondation. Zodiac Pool Systems, Inc. n'est pas responsable des pertes d'eau, des inondations ou des avaries causées par une installation ou un entretien inadéquat.

The LXi heater may be installed indoors or outdoors, as outlined in later sections. Location of the heater below *or above* the pool water level affects operation of its water pressure switch. See sections on water piping and heater start-up for more information about this.

Avoid placing the heater in locations where it can cause damage by water or condensate leakage. If this is not possible, provide a suitable drain pan to catch and divert any leakage. The pan must not restrict the air flow around the heater.

All criteria given in the following sections reflect minimum clearances as stated in the national standards. However, each installation must also be evaluated, taking into account the prevailing local conditions such as wind speed and direction, proximity and height of walls that may block ventilation, and proximity to public access areas.

2.3.2 Clearances

The heater must be placed to provide clearances on all sides for maintenance and inspection. There must also be minimum distances maintained from combustible surfaces. See Table 2.

At least 18 inches (457mm) access must be available in front of the heater for burner removal and access to the igniter.

If the heater is to be installed in a garage, or sim-

Table 2. Minimum Heater Clearances From Combustible Surfaces
Table 2. Dégagements Minimaux à Assurer Entre les Parois de L'appareil et les Constructions Combustibles

SIDE OF HEATER	INDOOR (OUTDOOR SHELTER) INSTALLATION		OUTDOOR INSTALLTION	
	INCHES	CENTIMETERS	INCHES	CENTIMETERS
BLANK	8	20.3	8	20.3
REAR	4	10.2	4	10.2
PIPING	16	40.6	16	40.6
TOP	36	99.0	OPEN UNROOFED AREA	
FRONT	18*	45.7*	18*	45.7*

Note: Clearances listed in Table 2 are manufacturer's tested values. These are given as minimum values. Where local and national codes apply, and values are different than those listed in Table 2, use the greater value to ensure safe operation.

* In Canada - 24 in (61 cm)

ilar structure, all burners and burner ignition devices must have a minimum 18 inches (457mm) clearance above the floor.

This heater must be installed at least 5 feet (1.52m) from the inside wall of a pool unless the heater is separated from the pool by a solid fence, wall or other permanent solid barrier.

Ce chauffe-piscine doit être installé au moins 5 pieds (1.52m) de la paroi interne de la piscine à moins d'être isolé de la piscine par une clôture, un mur ou autre barrière permanente.

2.3.3 Flooring

The heater must be installed on a **level** surface of noncombustible construction or on fire-resistant slabs or arches. Noncombustible flooring is defined as flooring material and surface finish not capable of being ignited and burning and with no combustible materials against the underside. Acceptable materials are those consisting entirely of a combination of steel, iron, brick, tile, concrete, slate, glass or plaster. **Do not** install the heater directly on a combustible wood or carpet floor without placing a noncombustible platform between the floor and the heater.

The heater can be installed on a combustible floor if a noncombustible base assembly, available from Zodiac Pool Systems, Inc., is used. See the heater rating plate or the Parts List (*Section 11*) in this manual for the appropriate base part number. **Heaters must never be installed directly on carpeting.**

As an alternative to the Jandy noncombustible base plate, in the United States, the National Fuel Gas Code (NFPA 54 / ANSI Z223.1), and in Canada, the Natural Gas and Propane Installation Code (CAN/CSA-B149.1), allow a heater to be placed on a combustible surface when there is a platform under the heater made of hollow masonry no less than 4 inches (102 millimeters [mm]) thick, covered with sheet metal at least 24 gauge thick and extending beyond the full width and depth of the heater by at least 6 inches (153 mm) in all directions. The masonry must be laid with ends unsealed, and joints matched to provide free circulation of air from side to side through the

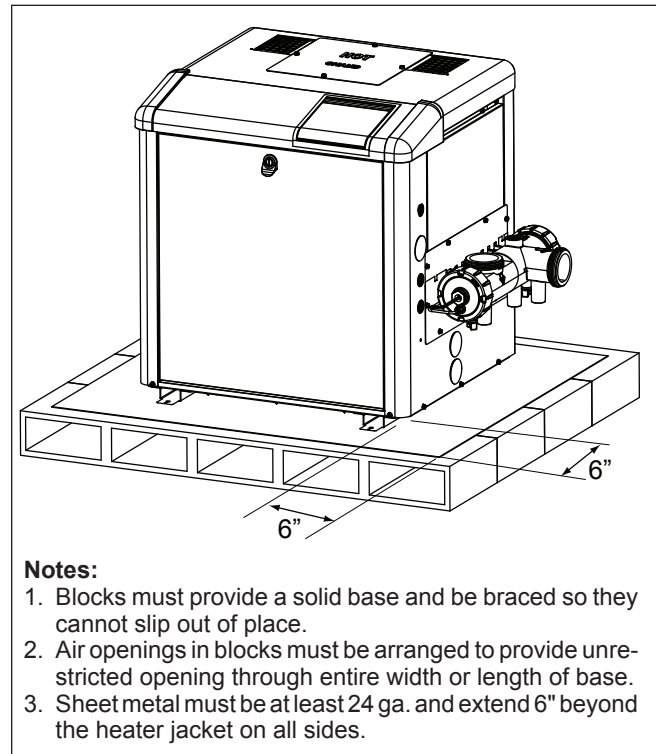

Figure 2. Noncombustible Platform

masonry. (See Figure 2.) If the heater is installed in a carpeted alcove, the entire floor of the alcove must be covered by a noncombustible panel.

2.3.4 Outdoor Installation

The LXi heater can be installed in the outdoor configuration as received from the factory.

Locate the heater in an **open, unroofed area**. Do not install the heater under a deck. Do not locate the heater below or adjacent to any doors, glass openings, louvers, grills, etc., which connect in any way with an inhabited area of a building, even though the access might be through another structure (e.g., a garage or utility room). In the United States the vent system shall terminate at least 4 ft (1.2 m) below, 4 ft (1.2 m)

horizontally from, or 1 ft (300 mm) above any door, operable window, or gravity inlet into any building. In Canada, the heater must be installed so that the exhaust point of the heater is at least 10 feet (3.0 m) from any building opening. See Figure 3.

<p>⚠ WARNING</p> <p>United States</p> <p>Do not install the heater with the top of the vent assembly within 4 feet (1.22 m) horizontally, 4 feet (1.22 m) below or less than 1 ft (300 mm) above of any opening into a building.</p>
<p>Canada</p> <p>Do not install the heater with the top of the vent assembly within 10 feet (3.05 m) of any opening into a building.</p>
<p>⚠ AVERTISSEMENT</p> <p>Lorsque vous installez l'appareil de chauffage, assurez-vous que l'ouverture d'aération se trouve à un minimum de 10 pieds (3.05 m) de toute ouverture d'un bâtiment.</p>

The top surface of the heater must be at least 3 feet above any forced air inlet, or intake ducts located within 10 feet horizontally.

If the heater is installed under an overhang, there must be a minimum clearance of 5 feet (1.5 m) above the top of the heater and the structure should not overhang the heater more than 12 inches (0.30 m). The area under the overhang must be open on three (3) sides. This prevents combustion gases from being diverted into living areas through doors, windows, or gravity inlets.

Ne pas installer ce chauffe-piscine sous une saillie mesurant moins de 3 pi de hauteur. La partie sous la saillie doit être ouverte sur 3 côtés.

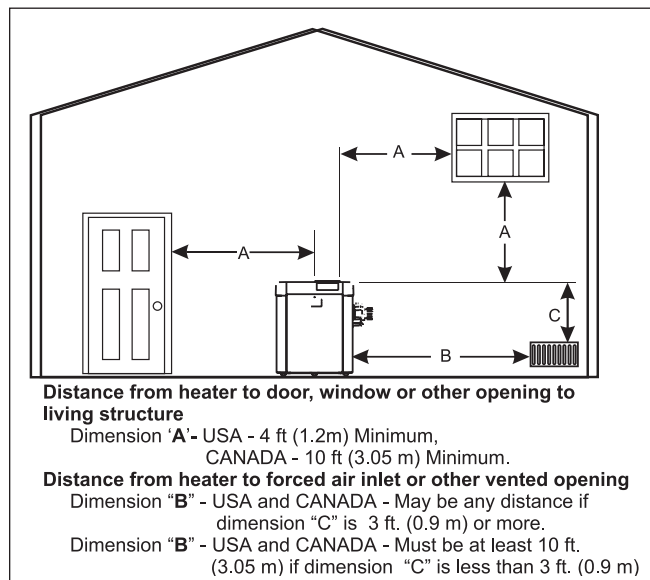

Figure 3. Outdoor Heater Installation

If the heater is installed close to a structure, protect it from rain water runoff with rain gutters on the roof or other measures. Do not locate the heater near irrigation sprinkler systems that could spray water on it. Water from sprinklers may cause damage to controls and electronic components.

Avoid locations where wind deflection off nearby structures might cause downdraft conditions. Where downdraft conditions exist, locate the heater at least 3 feet (0.91 m) from vertical surfaces (e.g., nearby buildings and walls).

In Florida, it is required that the heater be securely fastened to the equipment pad. Use a size 1/4 inch x 1-1/2 inch long stainless steel Tapcon® type concrete screws and washers at each of the four (4) tabs located at the base of the heater. Mounting the appliance in this manner meets the applicable requirements of the Florida Building Code.

Tapcon is a registered trademark of Illinois Tool Works, Inc.

Mounting screws are not provided with this heater. After placing the heater on the equipment pad, drill a hole in the concrete at each of the four (4) tabs on the feet of the heater. (The correct size drill bit is usually provided with the concrete screws when purchased). Place a screw in each of the holes and fasten the heater to the equipment pad. (See Figure 4). **Do not over-torque the screws.** Other jurisdictions may have similar requirements. Please check your local codes for relevant details.

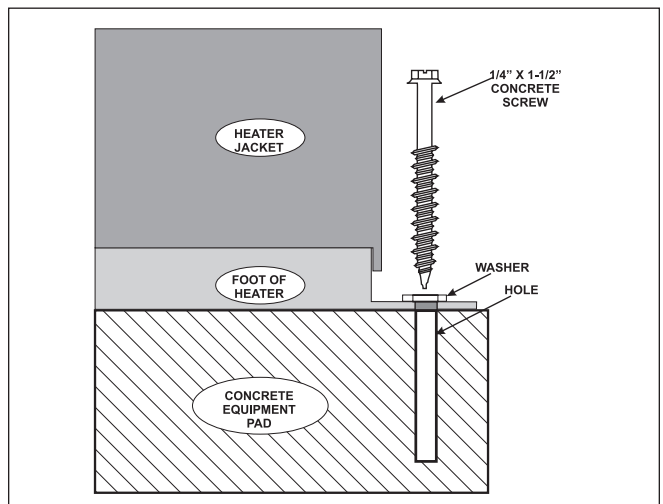

Figure 4. Anchor Heater To Equipment Pad

2.3.5 Indoor and Outdoor Shelter Installations

An outdoor shelter (Canada only) is an unoccupied enclosure which does not communicate directly with occupied areas. All indoor installations and outdoor shelter installations require a factory approved vent collar. The vent collar must be installed without modification and in accordance with the instructions provided by the manufacturer. For sidewall venting, a side vent kit is available from your Jandy distributor.

Une remise extérieure (au Canada seulement) est un endroit inoccupé qui ne communique pas directement avec les endroits occupés. Toutes les installations intérieures et remises extérieures exigent l'addition d'une cheminée approuvée par le fabricant. La cheminée doit être installée sans aucune modification et selon les exigences fournies par le fabricant.

The applicable codes, standards and Zodiac Pool Systems, Inc., require that the heater be properly vented as outlined in this manual. Proper ventilation of exhaust and combustion air are essential for the safe and efficient operation of the heater. See *Section 3*.

2.3.5.1 Converting the Grill to a Vent Collar

If the LXi heater is to be installed either indoors or in an outdoor shelter, its exhaust discharge grill must be removed. The LXi heater comes with the vertical vent collar factory installed. The optional side vent plate, gasket and screws can be ordered as a parts kit. (See the parts list in *Section 11* of this manual). The conversion can be done quite simply as follows:

1. Remove the vent exhaust grill by removing the four screws which retain it. The grill and the screws may be discarded. See Figure 5.
2. Install the vent pipe on the indoor vent collar. The collar will accommodate vent piping of nominal 6", 7" or 8" diameter (see Table 4), depending upon the model of your heater. (See Figure 6.) See vent installation section for important information on selecting proper pipe size.

Section 3. Venting

3.1 Combustion Air Supply

The heater location must provide sufficient air supply for proper combustion and ventilation of the surrounding area as outlined in the latest edition of ANSI standard Z223.1 (NFPA 54) or in Canada, CAN/CSA-B149.1, and any local codes that may be applicable.

In general, these requirements specify that the room in which a heater is installed should be provided with two (2) permanent air supply openings; one (1) within 12 inches (305 mm) of the ceiling, the other within 12 inches (305 mm) of the floor. All indoor installations must have openings to outside air for combustion, ventilation, and dilution of flue gases from inside the building. See Figure 7 and Table 3. Zodiac Pool Systems, Inc., does not recommend indoor installations that do not provide combustion air from outside the building.

All outdoor shelter installations (Canada only) must have uninterrupted openings to outside air for combustion and ventilation. The installation must be in accordance with the latest edition of CAN/CSA B149.1. Zodiac Pool Systems, Inc., does not recommend outdoor shelter installations that depend on internal air for combustion. Combustion air should be ducted to the heater from outside the structure.

Outside Air Supply: When combustion air is supplied directly through an outside wall, each opening should have a minimum free area of 1 square inch per 4,000 BTU/h (1.2kW) input of the total input rating of all appliances in the enclosed area. If air is provided through horizontal ducts, each opening and duct must provide 1 square inch of flow area for each 2000 BTU/h (0.6 kW). These requirements are summarized in Table 3. Note that the areas specified are net free areas and should be increased when the openings are covered by screens, louvers, grills or other protective covers. See Figure 8 and Table 3 notes.

Note In Canada, follow Canadian Standard, CAN/CSA-B149.1 or local codes.

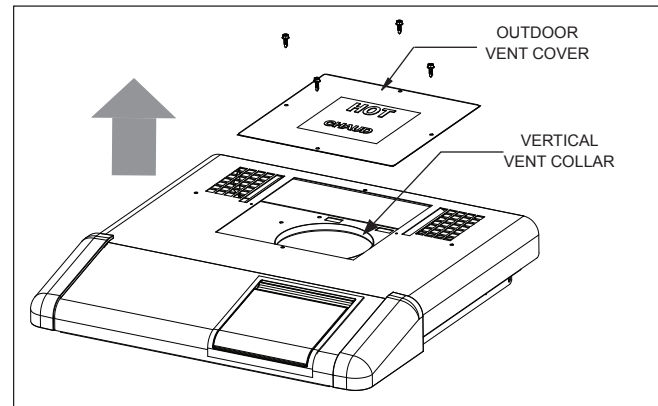

Figure 5. Removal of Outdoor Exhaust Grill

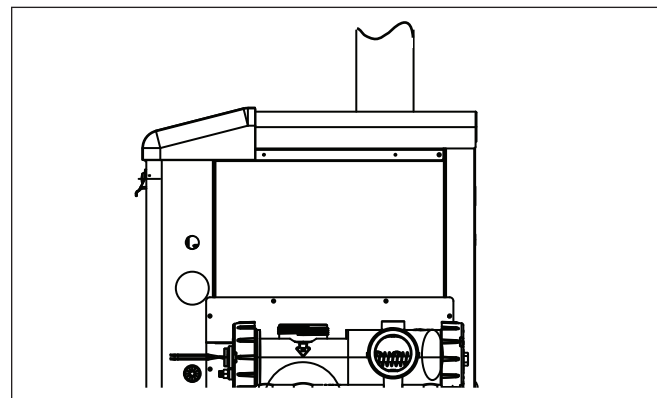

Figure 6. Vent Pipe Installation

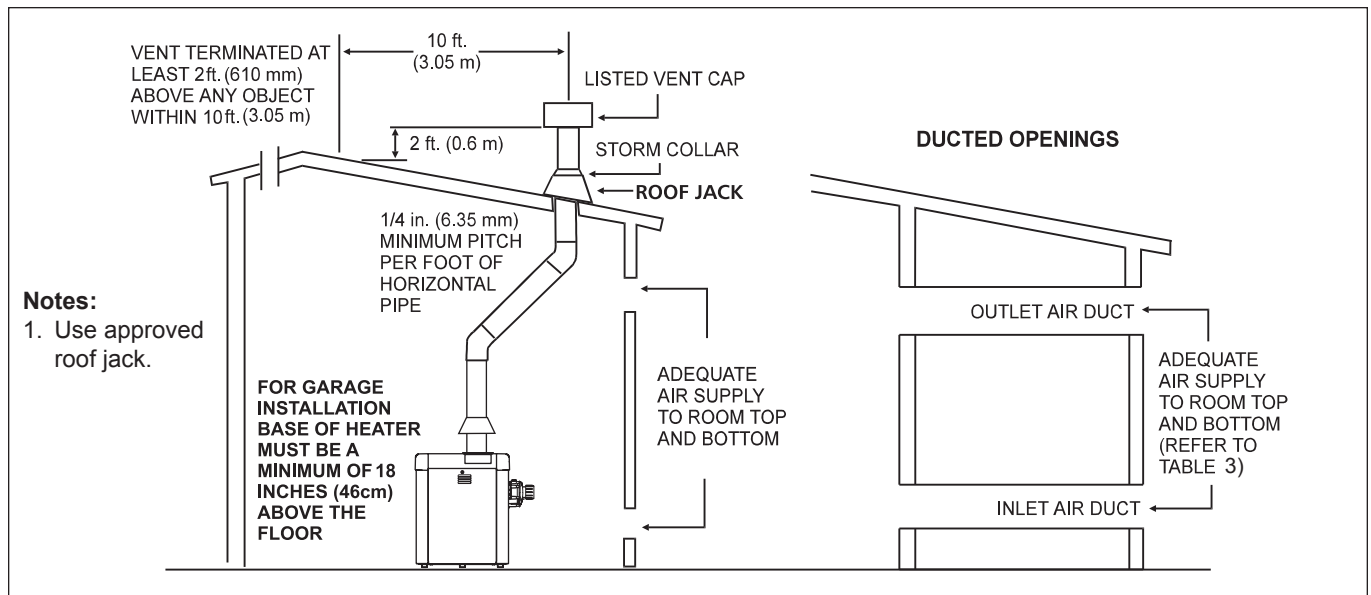

Figure 7. Indoor Installation Venting (USA), or Outdoor Shelter (Canada)

Table 3. Air Openings to Outside

Model	Required Net Free Open Area* for Combustion Air Openings			
	Direct from outside		Duct from outside	
	in ²	(cm ²)	in ²	(cm ²)
250	63	(406)	126	(813)
300	75	(484)	150	(968)
400	100	(645)	200	(1290)

*Area indicated is for one (1) of two (2) openings; one (1) at floor level and one (1) at the ceiling, so the total net free area would be double the figures indicated. For special conditions, refer to NFPA54 ANSI Z223.1. In Canada refer to the National Standard CAN/CSA-B149.1 which differs from this table.

Note: If using screens and/or metal louvers, compensate by adding 50% additional area to each opening. If using wood louvers each opening must be at least four (4) times the area indicated in the table above.

Exhaust Fans or Vents: Any equipment which exhausts air from the room where the heater is installed can deplete the combustion air supply or reverse the natural draft action of the venting system. This could cause flue products to accumulate in the room. Additional air must be supplied to compensate for such exhaust.

The information in Table 3 is not applicable in installations where exhaust fans or blowers of any type are used. Such installations must be designed by qualified engineers.

The heater must be completely isolated and protected from any source of corrosive chemical fumes such as those emitted by trichlorethylene, perchloroethylene, chlorine, etc.

⚠ WARNING

Do not store any chemicals, cleaners, or other corrosive material near combustion air openings or in the room. Avoid locating appliance vents in the vicinity of combustion air openings. Failure to prevent corrosive materials from mixing with combustion air can result in reduced heater life and unsafe heater operation.

⚠ AVERTISSEMENT

Ne pas entreposer ni utiliser d'essence ni d'autres vapeurs ou liquides inflammables à proximité de cet appareil ou de tout autre appareil.

3.2 Exhaust Venting

When converted to indoor and outdoor shelter venting configuration, the LXi heater has a vent collar fitting for attachment to the venting for Category I vertical venting. The diameter of the vent collar and, thus, the minimum diameter of the vent pipe to be used is determined by the model of heater installed and the type of venting. **The only correct procedure for vent pipe sizing is to do so in accordance with Table 4 and the applicable installation code as stated in the following "Warning" warning.** Note that with horizontal Category III type vent installations, the venting may be smaller than the vent collar for Category I vertical venting. See Table 4. Category III vent collars are available separately.

Table 4. Vent Pipe Sizing Table

Heater Size	Category I				Category III						
	Vent Pipe Diameter		Minimum Vertical Vent Pipe Diameter (Refer to NFPA 54 or local codes)		Vent Pipe Diameter		Maximum Horizontal Vent Length		Maximum No. of Elbows	Category III Sidewall Vent Kit	Category III Vertical Vent Kit
250	6 in	15 cm	6 in	15 cm	5 in	13 cm	25 ft	7.6 m	3	R0467301	R0484301
300	7 in	18 cm	7 in	18 cm	5 in	13 cm	25 ft	7.6 m	3	R0467302	R0484302
400	8 in	20 cm	8 in	20 cm	6 in	15 cm	25 ft	7.6 m	3	R0467303	R0484303

WARNING

Vent pipe diameter must be as required by the National Fuel Gas Code Z223.1 or the Canadian Installation Codes for Gas Appliances CAN/CSA-B149.1. Undersized pipe can result in inadequate venting and oversize pipe can result in vent condensation. In either case the result can be release of combustion products to the indoors. This can cause serious injury or death by carbon monoxide poisoning or asphyxiation.

AVERTISSEMENT

Le diamètre des tuyaux de ventilation doit répondre aux exigences du *National Fuel Gas Code* Z223.1 ou du code canadien des installations des appareils à gaz CAN/CSA B149.1. Des tuyaux trop petits risquent d'entraîner une ventilation inadéquate et des tuyaux trop gros risquent de provoquer une condensation dans les tuyaux. Dans un cas comme dans l'autre, des produits de combustion risquent de s'échapper dans le bâtiment et causer des blessures graves ou l'asphyxie par le monoxyde de carbone.

All vent installations must be made in accordance with all local, state or provincial codes and with:

1. The National Fuel Gas Code, ANSI Z223.1 (NFPA 54), latest edition; pay particular attention to the chapter addressing "Venting of Equipment." Applicable provisions of additional applicable local building codes may also need to be followed.
2. In Canada, CAN/CSA B149.1.

In all installations, avoid terminating heater vents near air conditioning or air supply fans. The fans can pick up exhaust flue products from the heater and return them inside the building, creating a possible health hazard.

Do not locate the vent terminal where flue products could strike against building materials and cause degradation.

Vent opening should be well away from trees or other obstructions that would prevent free air flow to and from vent terminal. Do not terminate the vent under decks, stairways, or car ports.

The LXi may be installed for use with standard Category I venting per tables provided in most local codes for Category I Fan-Assisted appliances. If the local code does not include such tables, refer to the National Fuel Gas Code NFPA 54 / ANSI Z223.1 or the Canadian Natural Gas and Propane Installation Code, CAN/CSA-B149.1. Note that the tables for fan-assisted appliances include both maximum and minimum vent loading figures. The primary purpose of the maximum ratings are to assure that the vent operates with negative pressure throughout its length. The minimum ratings are to assure that vent gases do not cool too much and thereby assure that condensation does not occur.

When the installation requires horizontal venting in excess of what is allowed for Category I installations or calls for horizontal discharge, the LXi may be installed with a Category III venting system. Category III applications must be installed per this installation manual and the vent manufacturer's installation instructions. The venting materials must comply with UL 1738 for Category III venting systems and be constructed of stainless steel. In Canada, the venting materials must be ULC S636 compliant. Vent piping must be adequately supported with no low spots or sagging that will allow condensate to collect. The heater must not be used to support the vent pipe. Horizontal runs

3.3 Vent Pipe Sizing and General Installation

The LXi may be installed with venting as a Category I or III Fan-Assisted appliance or outdoors with the integral vent grill.

3.3.1 Outdoor Installations

For outdoor installations, exhaust venting considerations will determine the placement of the heater (See Section 2.3.4). If the heater cannot be placed so as to meet the requirements stated in Section 2.3.4, a vent collar may be added to the heater to move the exhaust vent opening to a position that complies with the requirements. In all cases, vent collars must be of the same diameter as the exhaust outlet of the heater. Approved vent collars may be obtained through your Jandy distributor.

3.3.2 Indoor and Outdoor Shelter Installations

All indoor installations and outdoor shelter installations require a factory approved vent collar. The vent collar must be installed without modification and the Category I vertical vent collar comes factory installed.

must be sloped upwards away from the heater to a vent terminal at a minimum of 1/4 inch per horizontal foot (2 cm/m). The LXi is designed for Category III venting with a maximum of 25 ft (7.6 m) of vent pipe and up to three (3) elbows. For each additional elbow, reduce the maximum vent pipe length by 10 ft (3 m). See Table 4 for the minimum vent diameter for the model size to be installed.

Side wall vents must be installed and located in accordance with the National Fuel Gas Code NFPA 54 / ANSI Z223.1 or the Canadian Natural Gas and Propane Installation Code CAN/CSA-B149.1. See Figure 8 Side Wall Vent Terminations.

IMPORTANT NOTE In the Commonwealth of Massachusetts, additional requirements, covered in document CMR 248 5.00, which supersede some of the requirements of ANSI Z223.1 (NFPA 54) apply to Side Wall Horizontally Vented appliances. If installing this product using an approved side-wall horizontal vent system in the Commonwealth of Massachusetts, be sure to adhere to these additional requirements. These requirements include verbiage that says that the property owner is to ensure that Carbon Monoxide Detectors are installed in the vicinity of the appliance and also on all levels of the dwelling in which the appliance is installed. For further instructions, contact Zodiac Pool Systems, Inc., Technical Support Department at 800.822.7933.

NOTE For approved side wall vent kits and specific installation instructions, see *Section 11, Replacement Parts*.

Zodiac Pool Systems, Inc. does not recommend using a "Common Vent" to vent multiple appliances through a common duct. However, if no other option is deemed available by the installer, each appliance must have its own vent temperature limit switch. All vent limit switches must be wired in series so as to prevent any appliance from firing in the event of a blocked vent. Refer to ANSI Z223.1 or, in Canada, to CAN/CSA B149.1 for more information on multiple venting. Do not connect vent systems of different categories to the same venting system. Seek the assistance of a Registered Professional Engineer for proper design of a common venting system.

3.3.3 Inspection and Replacement of Existing Vent System with New Components

If the LXi is being installed to replace an existing pool heater, it is recommended that a new appropriate venting system be installed with the new heater. However, if an existing venting system must be used, be sure to carefully inspect the venting system to ensure that it is in good condition and continues to be appropriate for the LXi heater. Replace any parts that are not in good and serviceable condition with new parts before completing the pool heater installation.

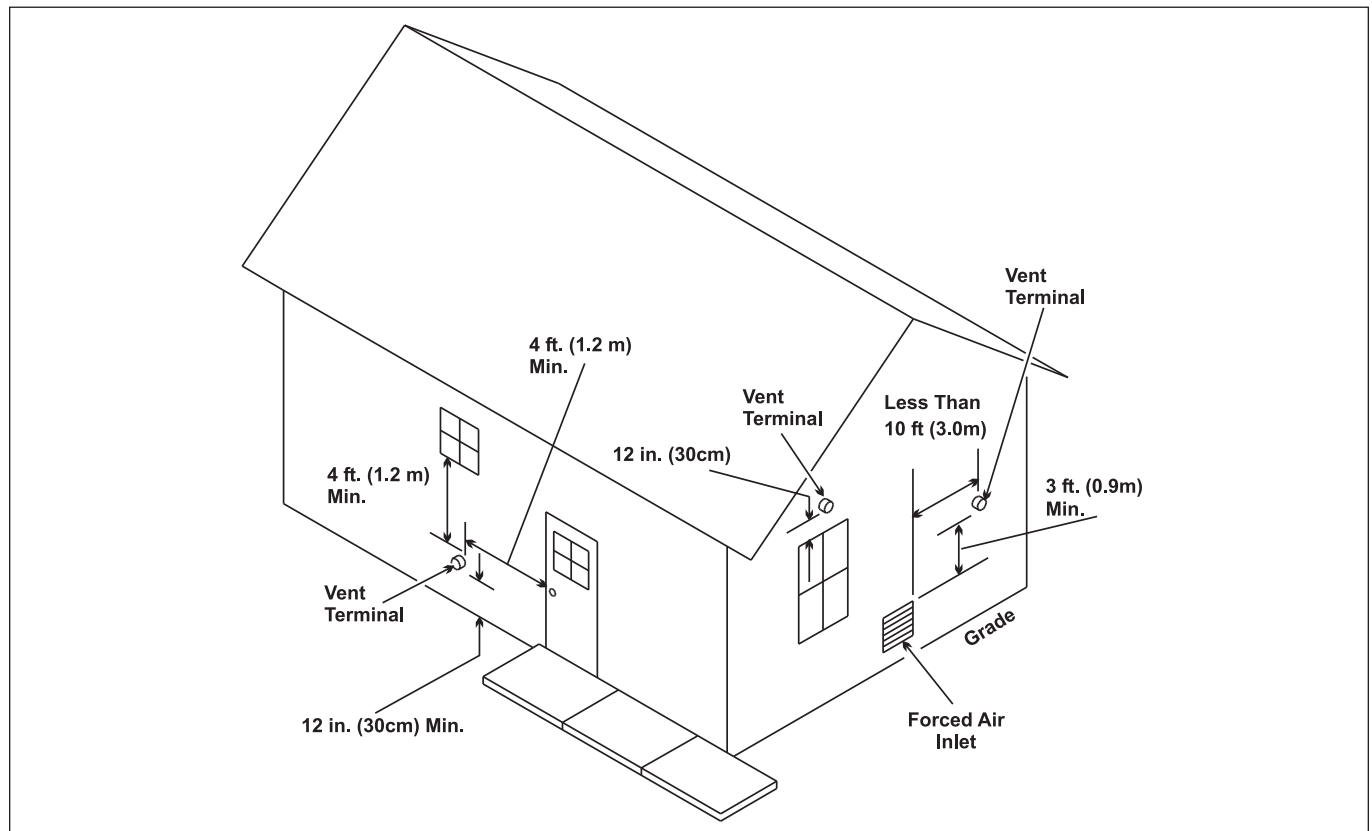

Figure 8. Side Wall Vent Terminations

Section 4. Gas Connections

4.1 Gas Supply and Piping

Review the following general instructions before continuing the installation.

⚠ WARNING

The LXi pool and spa heaters are designed for use with either natural gas or LP gas. Check the rating plate on the inner panel to be sure that the heater is designed to use the type of gas being supplied. **DO NOT ATTEMPT TO CONVERT THIS HEATER FOR USE WITH ANY OTHER TYPE OF FUEL.**

⚠ AVERTISSEMENT

Les appareils de chauffage à faibles émissions LXi pour piscines et cuves thermales sont conçus pour être utilisés avec du gaz naturel ou du gaz de pétrole liquéfié (GPL). Vérifiez l'information inscrite sur la plaque signalétique du panneau intérieur pour vous assurer que l'appareil est conçu pour le type de gaz fourni. **NE PAS ESSAYER DE CONVERTIR CET APPAREIL À UN AUTRE TYPE DE GAZ.**

1. Gas piping installation must be in accordance with the latest edition of ANSI Z223.1 and all local codes. In Canada, the installation must be in accordance with CAN/CSA B149.1 and all local codes that apply.
2. Check the gas supply to be sure that it is the same as the gas indicated on the heater's rating plate. LXi heaters, as shipped from the factory, are set to operate within the low altitude range. Follow the instructions in *Section 10.4.3* to adjust the heater for high altitude.

⚠ CAUTION

Permanent damage to the gas valve will occur if the following procedures are not followed.

⚠ ATTENTION

Vous endommagerez la soupape de gaz si vous ne respectez pas les procédures suivantes.

3. Use the figures in Table 5 to size the gas inlet piping from the gas meter to the heater. Check all local codes for compliance before installing the heater.

Table 5. Supply Gas Pipe Size Requirements*

Heater Size	Distance from Gas Meter					
	0-50 feet (0-15 m)		50-100 feet (15-30 m)		100-200 feet (30-60 m)	
	in.	mm	in.	mm	in.	mm
250	1	25	1-1/4	32	1-1/4	32
300	1-1/4	32	1-1/4	32	1-1/2	38
400	1-1/4	32	1-1/2	38	1-1/2	38

Notes:

- *1. These numbers are for natural gas (0.65 Sp. Gr.) and are based on 1/2 inch (3.45 kPa) water column pressure drop. Check supply pressure with a manometer, and local code requirements for variations. **For LP gas, reduce pipe diameter by one size, but maintain a minimum 3/4 inch diameter.**
2. Check supply pressure and local code requirements before proceeding with work.
3. Pipe fittings must be considered when determining gas pipe sizing.

4. Install a sediment trap (drip leg) ahead of the gas controls. See Figure 9. Fit the trap with a threaded cap which can be removed for cleaning.
5. Install a manual gas shutoff valve for service and safety. Do not use a restrictive gas cock. **DO NOT USE FLEXIBLE GAS PIPING**, it will restrict the gas flow to the heater.
6. Disconnect the heater and its individual shutoff valve from the gas supply system during pressure testing of the system at pressures higher than 1/2 pounds per square inch (psi) (3.45 kilopascals [kPa]). If the test pressure is equal to or less than 1/2 psi (3.45 kPa), close the manual shutoff valve on the heater during the piping pressure test.
7. If the gas supply pressure is less than required, check for undersized pipe between the meter and the heater, a restrictive fitting, or an undersized gas meter. Gas supply pressures to the heater are listed in Table 6.

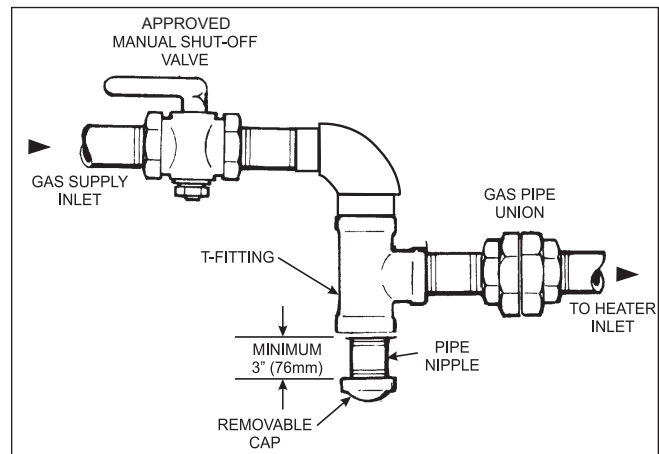

Figure 9. Proper Design for a Sediment Trap/Drip Leg

Table 6. Gas Supply Pressure Requirements*

Supply Pressure	Minimum	Maximum
Natural Gas	5.0 inches W.C. (1.2 kPa)	10.5 inches W.C. (2.6 kPa)
LP Gas	11.0 inches W.C. (2.5 kPa)	14.0 inches W.C. (3.5 kPa)
Manifold Pressure	Nominal	
Natural Gas	2.5 inches W.C. (0.6 kPa)	
LP Gas	9.0 inches W.C. (2.2 kPa)	

NOTE The maximum inlet gas pressure must not exceed the specified value. The minimum value listed is for the purpose of input adjustment. Refer to Table 6.

- To connect the gas supply line to the heater's gas valve, make sure the steel elbow (supplied with the manifold) is screwed into the inlet side of the gas valve. The heater is designed so that the gas supply line may enter through either side of the heater. Tighten the elbow until the desired orientation is achieved.

⚠ CAUTION

Do not overtighten the elbow. Over tightening will crack the gas valve. Do not use Teflon® tape to wrap the elbow threads.

⚠ ATTENTION

Ne serrez pas trop le coude. Vous risqueriez de fissurer la soupape de gaz. N'entourez pas le filetage des coudes de ruban à joints.

- Before operating the heater, test the complete gas supply system and all connections for leaks using a soap solution. Do not use an open flame.

⚠ CAUTION

Some leak test solutions (including soap and water) may cause corrosion or stress cracking. Rinse the piping with water after testing.

⚠ ATTENTION

Certaines solutions d'essai d'étanchéité (y compris l'eau et le savon) peuvent causer de la corrosion ou de la fissuration. Rincez les tuyaux à l'eau après l'essai d'étanchéité.

4.2 Manifold Pressure

Confirm that gas supply pressure is correct. If the gas supply pressure is less than required, check for undersized pipe between the meter and the heater, a restrictive fitting, or an undersized gas meter. Gas supply pressures to the heater, when it is operating, are listed in Table 6.

⚠ CAUTION

Manifold gas pressure for the LXi natural gas heaters should be set at **2.5" WC**. Propane heaters should be set to **9" WC**.

⚠ ATTENTION

La pression du collecteur de pression pour les systèmes de chauffage au gaz naturel devrait être de 2.5" WC. Pour les systèmes de chauffage au gaz propane devrait être de 9" WC.

The manifold pressure may be checked by connecting a manometer to the pressure port on the outlet side of the valve. The pressure will be zero when the heater is not running. When the heater is operating the manifold gas pressure should be 2.5" WC for natural gas heaters and 9.0" WC for LP gas heaters.

If the manifold pressure indicated above is not correct, check the gas train for possible problems. Check the meter, gas line, gas fittings, and gas shut off for under sizing. Check the gas valve inlet for excess pipe dope, if all is correct, then it may be necessary to adjust the gas valve regulator. To adjust the manifold gas pressure, first remove the slotted cap next to the inlet pressure port on the inlet side of the gas valve. Under the slotted cap is a slotted plastic screw which increases the manifold pressure when turned clockwise and decreases the manifold pressure when turned counterclockwise. After measurements, and adjustments if necessary, have been made, make sure to replace the 1/8 inch NPT gas valve plugs on the inlet and manifold pressure ports, and the cap on the manifold pressure adjustment screw. It is extremely important to replace these parts before leaving the installation. Failure to do so can result in damage to property or injury or death. *With the heater firing*, the pressure must be within the range shown in Table 6. Also check the pressure with the heater off.

⚠ WARNING

Failure to replace the 1/8 inch NPT gas valve plugs on the inlet and manifold pressure ports and the cap on the manifold pressure adjustment screw can result in property damage, severe injury, or death.

⚠ WAVERTISSEMENT

L'omission de remplacer les soupapes à gaz de 1/8 pouce NPT sur les lumières de refoulement de l'entrée et du collecteur et le capuchon sur la vis de réglage de pression du collecteur peut entraîner des dommages matériels, des blessures graves, voire la mort.

4.3 Special Precautions for LP Gas

LP Gas is heavier than air and can therefore more readily collect or "pool" in enclosed areas if provision for proper ventilation is not made. Installation of pool heaters in enclosed areas such as pits is not recommended. However, if such an installation is required be sure to pay special attention to proper ventilation requirements for LP gas. Locate heaters a safe distance from LP gas cylinders and filling equipment. Consult the National Fuel Gas Code (NFPA 54 / ANSI Z223.1, latest edition), the Natural Gas and Propane Installation Code in Canada (CAN/CSA B149.1, latest

edition), and any other local codes and fire protection authorities about specific installation restrictions in your area.

Section 5. Water Connections

5.1 Water Piping

Figure 10 illustrates typical piping for pool equipment in pool/spa combination pools. With its electronic control, the LXi heater is particularly suited for this type of pool installation.

The heater must be protected from back-siphoning of water, which can result in dry starts. If there is any chance of back-siphoning, provide a check valve between the pool and the filter pump inlet.

Arrangement of pool system components other than as illustrated in these diagrams can affect the operation of the heater's water pressure switch. Location of the heater above or below the pool water surface can also affect operation of the switch. In general, the pressure switch can be adjusted to accommodate this effect if the heater water connections are no more than 6 feet (1.8 m) below the pool water surface and no more than 15 feet (4.6 m) above it. See instructions for pressure switch adjustment (*Section 7.7*) for more information about this.

Note that when pool equipment is located below the pool surface a leak can result in large scale water loss or flooding. Zodiac Pool Systems, Inc., cannot be responsible for such water loss or flooding or the damage caused by either occurrence.

5.2 Check Valve Installation

Install a check valve in the plumbing between the pool inlet and the heater if there is any chance of back-siphoning.

Do not install any valve in the piping between the heater outlet and the pool, unless it is being used as a diverter valve. For special installations, such as water connections below the water level of the pool, or for other questions contact the Technical Service department at 800.822.7933.

5.3 Automatic Flow Control Valve

The inlet/outlet header of the LXi heater comes equipped with an automatic flow control valve. The automatic flow control valve maintains the proper flow through the heater at rates up to approximately 125 Gallons Per Minute (GPM) (475 liters per minute [LPM]). If the filter system flow rate is higher than approximately 125 GPM (475 LPM), install a manual bypass valve (see Figure 11), then perform a temperature rise test (see *Section 7.8*) and adjust the flow using the bypass valve until the proper temperature rise is obtained.

5.4 Reversible Water Connections

The LXi heater is shipped with water connections on the right side, but can be modified in the field to provide left-side water connections. This procedure involves removing the heat exchanger headers and reinstalling them on opposite ends of the tube assembly. Some of the heater wiring must be disconnected and re-routed, so this procedure must be done only by

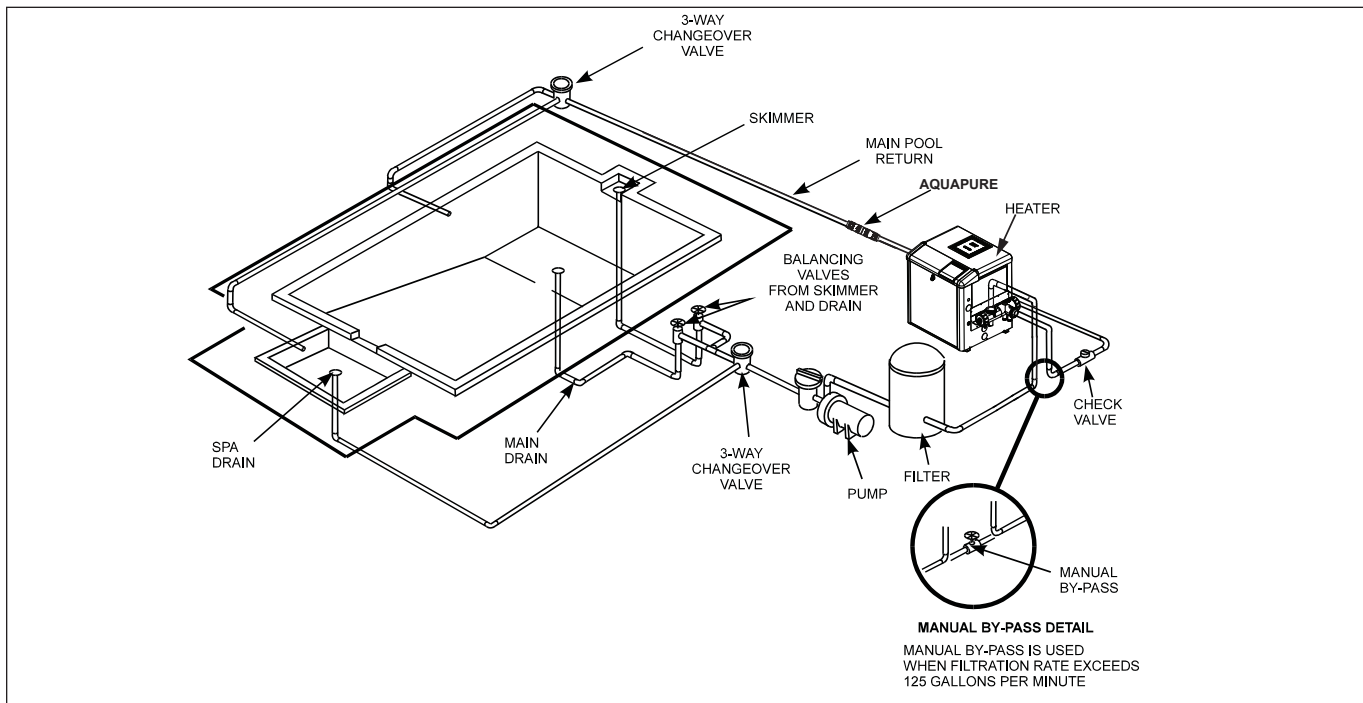

Figure 10. Typical Piping Installation

a trained service technician. Heat exchanger reversals are generally done before the installation of power and water to the heater. If you need to reverse the heat exchanger on a previously installed heater be sure that all electrical power, the gas supply and water supply have been turned off before starting the procedure. These instructions have been written to include the steps needed when reversing the water connections on an existing installation. If you are reversing the headers on a new installation, some steps will be ignored. Water connection reversal is illustrated in Figures 11 and 12. Proceed as follows:

1. For an existing installation, drain the heater by removing the two (2) drain plugs on the inlet/outlet header and the drain plug on the return header.
2. Remove the heater front panel (door).
3. Remove the I/O header side cover plates, top and bottom. See Figure 13.
4. Remove the return header side cover plate. See Figure 13.
5. Disconnect the blue "HiLimit" two-pin connector from the Power Interface board in the raceway. Clip any wire ties attached to the harness. Feed

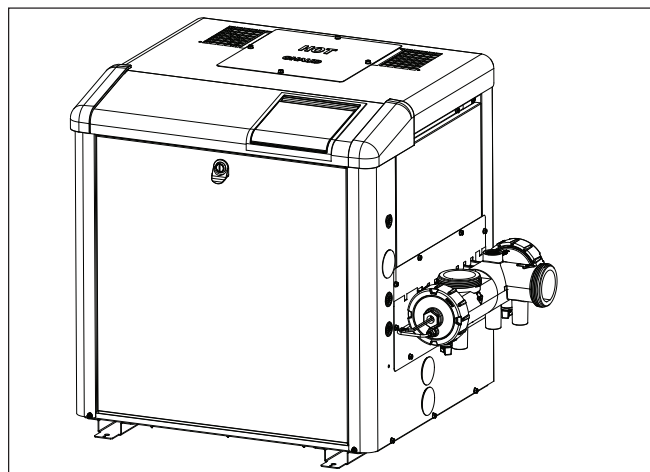

Figure 11. Water Connections as Shipped

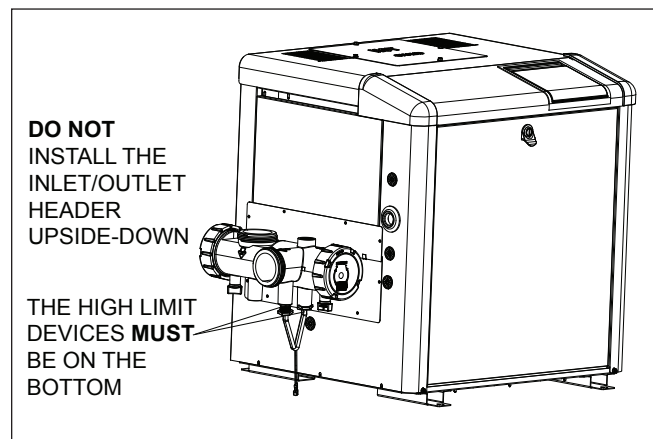

Figure 12. Water Connections Reversed

the "HiLimit" two-pin connector and wiring back through the way it is routed to the header so that the harness hangs free from the header, outside of the cabinet.

6. Disconnect the two (2) "WATER TEMP" temperature sensor leads from the Power Interface board in the raceway. Clip any wire ties attached to the harness. Pull the wires out of the cabinet so that they hang free from the header, outside of the cabinet.
7. Disconnect the yellow "Water Press" two-pin connector from the Power Interface board in the raceway. Clip any wire ties attached to the harness. Feed the "Water Press" two-pin connector and wiring back through the way it is routed to the water pressure switch so that the harness hangs free from the water pressure switch, outside of the cabinet.

NOTE Be careful not to create any kinks in the water pressure switch copper tubing when handling the header.

8. For an existing installation, remove the coupling nuts from the header and disconnect the water supply from the heater.
9. Remove the 10 bolts and washers from the inlet/outlet header and remove the header from the tube assembly.
10. Remove the 10 bolts and washers from the return header and remove the header from the tube assembly.
11. For an existing installation, remove the tube gaskets and clean the header's mating surface of

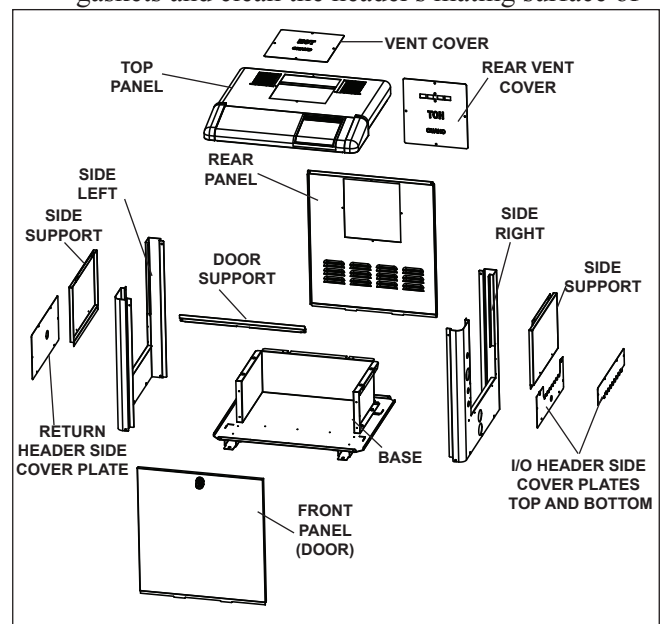

Figure 13. LXi Panel Identification

any corrosion or debris. Replace the tube gaskets with new ones. Do not use any metal tools on the header surface. Scratches may compromise the seal integrity.

⚠ WARNING

To avoid product failure which can cause property damage, serious personal injury or death, install the inlet/outlet header oriented so that the high limit devices are on the bottom.

12. Place the inlet/outlet header over the bolts and gasketed tubes on the left side of the tube assembly. Make sure the high limit devices are on the bottom. Align the bolt and tube holes in the header with the bolts and tubes in the header bar and slide the assembly together.
13. Thread on the 10 bolts and washers and hand tighten.
14. Place the return header over the bolts and gasketed tubes on the right side of the tube assembly. Align the bolt and tube holes in the header with the bolts and tubes in the header bar and slide the assembly together.
15. Thread on the 10 bolts and washers and hand tighten.
16. Use a torque wrench to tighten the bolts on each header to 4 foot-pounds. The bolts must be tightened in the sequence indicated in Figure 14.

⚠ CAUTION

Failure to tighten the header as indicated in step 16 may cause the header to leak or become permanently damaged from warping.

⚠ ATTENTION

Si le tuyau collecteur n'est pas serré conformément aux directives de l'étape 16, il risque d'avoir des fuites ou de s'endommager de façon permanente.

17. Remove the 3/4 inch button plug located in the left side panel below the inlet/outlet header and replace with the 3/4 inch wire grommet from the right side panel below the return header. The

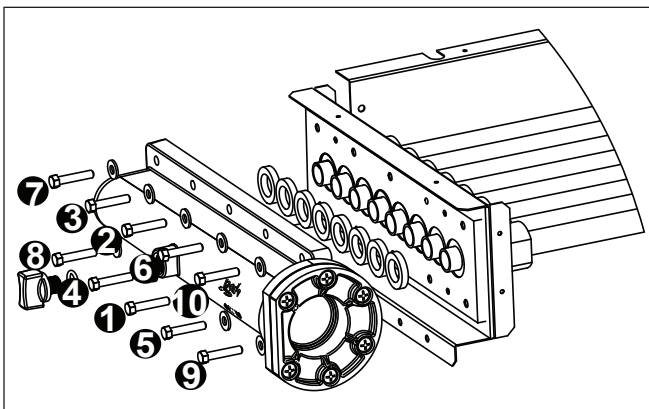

Figure 14. Header Bolt Tightening Sequence

high limit leads were routed through this grommet prior to removal in step 5. Install the 3/4 inch plug in the opening where the 3/4 inch wire grommet was removed.

18. Route the blue two-pin connector attached to the high limit switches back to the Power Interface board in the raceway. Reconnect the blue “Hi-Limit” two-pin connector to the blue “HiLimit” connector on the Power Interface board.
19. Route the wires that attach to the temperature sensor back to the Power Interface board in the raceway. Reconnect the wires to the “WATER TEMP” terminals on the Power Interface board.
20. Route the yellow two-pin connector that connects to the water pressure switch back to the Power Interface board in the raceway. Reconnect the yellow two-pin connector to the yellow “Water Press” connector on the Power Interface board.
21. Use plastic wire ties to refasten the temperature sensor, high limit switch and water pressure switch wires to each other. Bundle the wires near the control panel and fasten them with a wire tie.

NOTE Be sure that none of the wires are in contact with a sharp edge or a hot surface.

22. Install the return header side cover plate on the right side of the unit.
23. Install the I/O header side cover plates, top and bottom on the left side of the unit.
24. Replace the front panel (door).

5.5 Connections at Heater

The LXi heater has a standard 2 inch water header and coupling design. With this feature, only nominal two inch PVC or CPVC may be connected to the heater. However, by installing the appropriate pipe adapters and two (2) short pieces of two-inch plastic pipe (supplied by the installer), any size existing pipe may be fitted to the heater.

The LXi heater also comes with a Jandy Sweep Elbow for increased hydraulic performance and efficiency. The sweep elbow also provides the advantage of its exclusive interface with the Jandy AquaLink® RS temperature sensor.

To install the Jandy Sweep Elbow follow these instructions:

⚠ WARNING

To avoid an electrical shock hazard, which can result in serious injury or death, ensure that all electrical power to the system is turned off before approaching, inspecting or troubleshooting any leaking valves or plumbing that may have caused other electrical devices in the surrounding area to get wet.

⚠ WARNING

Follow all filter manufacturer's instructions. **NEVER** attempt to assemble, disassemble or adjust the filter when there is pressurized air in the system. Starting the pump while there is any pressurized air in the system can cause the filter lid to be blown off, which can cause death, serious personal injury or property damage.



1. Turn off the electrical power to the heater. Turn off the main gas supply to the heater at the meter or the manual gas cock outside the heater.
2. Be sure that the filter pump is OFF and that it will remain off during the entire procedure.
3. Open the relief valve on top of the filter and leave it open during the procedure.
4. If the heater is below the surface level of the wa-

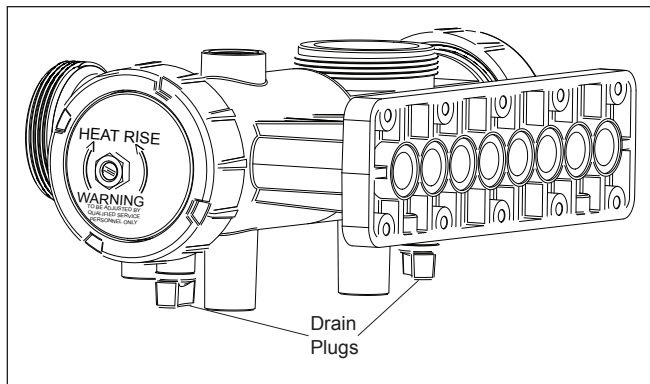

Figure 15. Header Drain Plug Location

ter in the pool or spa, be sure to close all shut-off valves between the heater and the pool.

5. Remove the drain plugs and drain the heater. See Figure 15.

NOTE: Be sure to use 2 inch or 2½ inch schedule 40 PVC pipe.

6. Clean the cut ends of the pipe and both ends of the sweep elbow(s) with an appropriate NSF® approved All Purpose cleaner/primer. Glue the sweep elbow(s) onto the cut pipe ends using an appropriate All Purpose NSF® approved adhesive/glue. See Figure 16.

NOTE: Zodiac Pool Systems, Inc. recommends Weld-On 724 PVC to CPVC Cement to glue Schedule 40 PVC.

7. After the glue is cured, close the pressure relief valve on top of the filter, start the system and check for proper water flow.
8. Replace the drain plugs.
9. Return all valves to their operating positions.
10. Restore power to the heater.
11. Turn on the pump to check for water leaks.
12. Restore the gas supply to the heater.

To connect a section of 2 inch PVC or CPVC pipe to the heater, first slip a coupling nut onto the pipe. Then prepare the end of the pipe with the proper PVC/CPVC primer and glue. Follow the manufacturer's instructions provided with the primer and glue

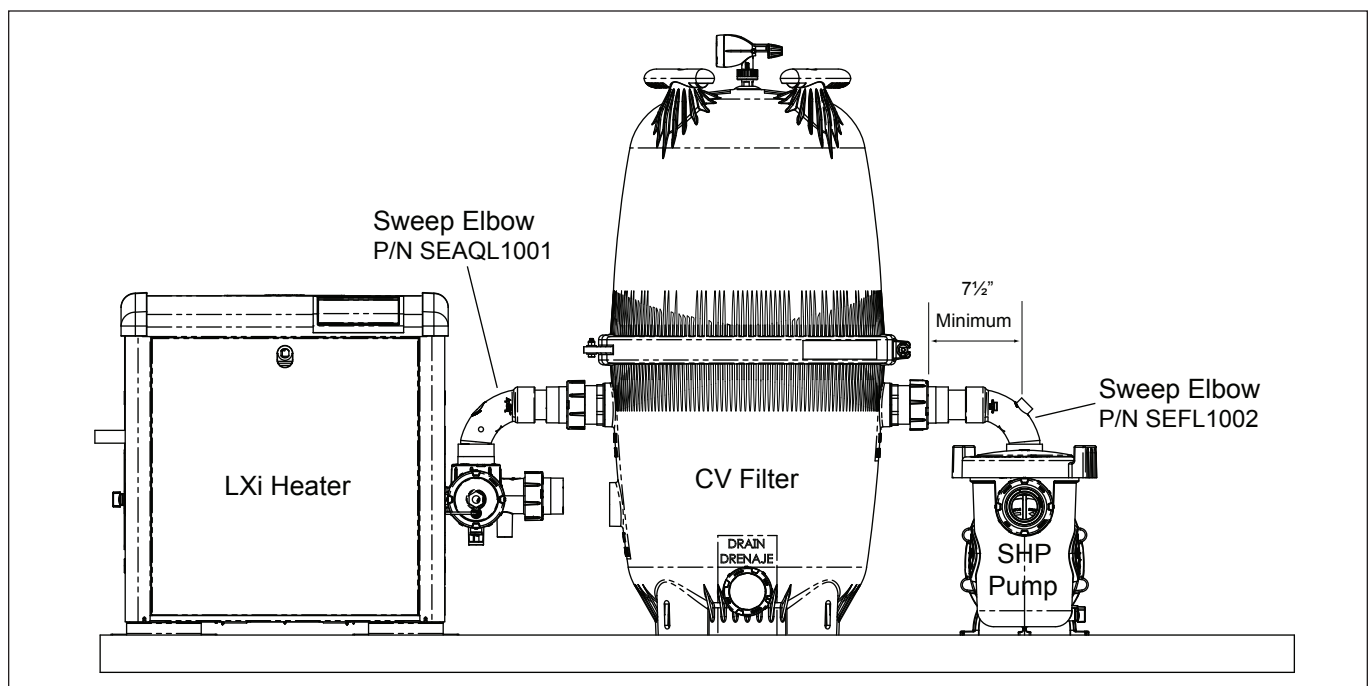

Figure 16. LXi Heater Sweep Elbow Installation

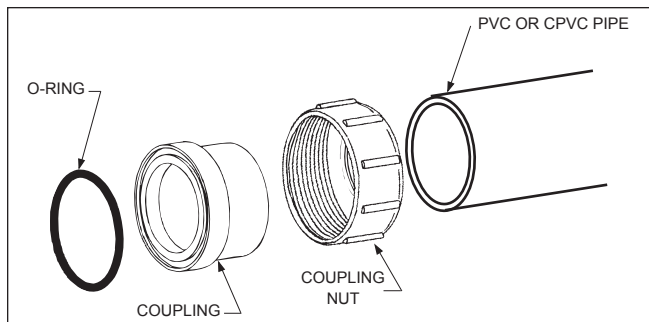

Figure 17. Piping to Heater

for preparation procedures and curing times. Apply the slip-fit side of the coupling to the end of the pipe. Allow the glue to cure completely. Set the o-ring into the groove on the face of the coupling. Slide the coupling nut up to the coupling and tighten it to the threaded connection on the header. See Figure 17.

5.6 Pressure Relief Valve

A pressure relief valve (PRV) is recommended in all installations, and is mandatory in any installation in which the water flow can be shut off between the heater outlet and the pool/spa.

A pressure relief valve is not supplied with the LXi heater. However, it is recommended that a pressure relief valve be installed and may even be required by local codes. Be sure to check any applicable installation codes in your area to determine whether a pressure relief valve is required. See *Section 11.2* (Parts List) of this manual for the appropriate kit part number.

The maximum working pressure of this heater is 75 psi. Be sure to take into consideration the maximum allowable pressure of the other components in the system when selecting a PRV. Any pressure relief valve installed must comply with provisions of the standard described in ANSI Z21.22 for the United States or CSA 4.4 in Canada.

Follow these steps to install a pressure relief valve:

1. To protect the threads while drilling, screw the brass adapter (included with the Jandy PRV kit) into the blind threaded hole on the top of the inlet/outlet header.
2. Using the countersink in the center of the blind hole as a guide, drill a 1/4 inch hole through the plastic. See Figure 18.
3. Open the hole by reaming it with a 3/8 inch drill bit.
4. Open the hole again by reaming it with a 1/2 inch drill bit.

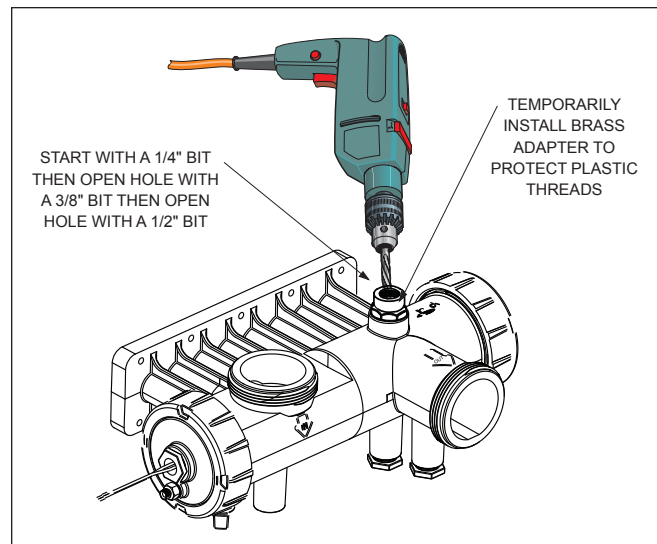

Figure 18. Drill Hole for Pressure Relief Valve

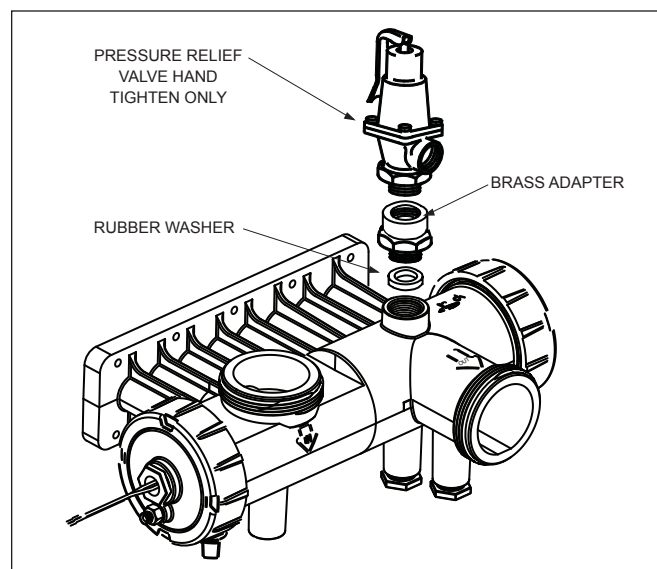

Figure 19. Pressure Relief Valve Installation

⚠ CAUTION

Initially drilling a 1/2 inch hole without reaming may cause the bit to "grab" on the plastic. This may cause personal injury or damage the plastic header.

⚠ ATTENTION

Si vous commencez à percer le trou de 1/2 pouce sans alésage préalable, la mèche risque de « mordre » dans le plastique. Vous risquez de vous blesser ou d'endommager le tuyau collecteur de plastique.

5. Remove the brass adapter and clean the cuttings out of the hole.
6. Install the rubber washer at the bottom of the hole. See Figure 19.
7. Thread the adapter into the hole and tighten so that it seals against the rubber washer.
8. With a permanent marker, place a mark on the

- adapter so that the mark faces the same direction as the water connections on the header.
9. Remove the adapter from the hole.
 10. Coat the threads of the pressure relief valve (PRV) with an appropriate metal to metal thread sealant.
 11. Install the adapter on the PRV and tighten using two (2) wrenches. Use the mark made earlier on the adapter to orient the PRV to the desired direction in relation to the water connections on the header.
 12. Wrap the threads of the adapter with a suitable teflon thread tape.
 13. Reinstall the adapter, with the PRV, into the plastic threaded hole and tighten it until the mark on the adapter is once again facing the same direction as the water connections on the header.

<p>⚠ CAUTION</p> <p>Do not use any pipe compound or pipe dope on the threads of the adapter or any part that comes in contact with the plastic headers. These compounds may damage the header over a period of time.</p>
<p>⚠ ATTENTION</p> <p>N'utilisez ni pâte à joint ni pâte lubrifiante sur le filetage du raccord intermédiaire ou sur toute pièce qui entre en contact avec le tuyau collecteur. Ces produits risquent d'endommager le tuyau après un certain temps.</p>

DO NOT TIGHTEN WITH A WRENCH.

Overtightening may crack the header. Route the discharge piping so that discharge from the pipe does not endanger anyone near the heater. Refer to your local installation codes for more detailed information. The valve setting should be at or below the maximum working pressure of any component in the filter system. The maximum working pressure of the LXi heater is 75 psig.

5.7 Auxiliary Components, Chlorinators, Ozone Generators, and Sanitizing Chemicals

The LXi heater is manufactured with materials that are not compatible with high concentrations of ozone, chlorine, bromine, or other sanitizing chemicals. Heater damage caused by excessive chemicals or improper ozonization is not covered by the Zodiac Pool Systems, Inc., warranty. Be sure to adhere to the following:

- When ozone is injected upstream of the heater, install an offgas mixing chamber, or an ozone bypass system between the heater and the ozone injector to prevent ozone and air from entering the heater.

- When chemical feeders are used, plumb the feeder downstream of the heater and install an in-line check valve between the heater and the feeder (a minimum of 18 inch is required between the heater and the check valve).
- Wire any electrical chemical feeder so that it cannot operate unless the filter pump is running. If the feeder has an independent clock control, synchronize it with the filter clock.
- Never deposit chemicals directly in the pool skimmer.

Section 6. Electrical

<p>⚠ WARNING</p> <p>ELECTRICAL SHOCK HAZARD. This heater contains wiring that carries high voltage. Contact with these wires may result in severe injury or death.</p>
<p>⚠ AVERTISSEMENT</p> <p>POSSIBILITÉ DE CHOCS ÉLECTRIQUES. Ce système de chauffage contient du filage de haut voltage. Un contact avec ces fils peut résulter en des blessures sérieuses ou la mort.</p>
<p>⚠ CAUTION</p> <p>Label all wires prior to disconnection when servicing controls. Wiring errors can cause improper and dangerous operation. Verify proper operation after servicing.</p>
<p>⚠ ATTENTION</p> <p>Au moment de l'entretien des commandes, étiquetez tous les fils avant de les débrancher. Des erreurs de câblage peuvent entraîner un fonctionnement inadéquat et dangereux.</p>

6.1 General Information

Wiring connections must be made exactly as shown in the wiring diagram found on the inside of the heater door. See Figure 20. The heater must include a definite means of grounding. There is a bonding lug on the right side of the heater, where a bond wire must be attached.

6.2 Main Power

Electrical wiring must be in accordance with the latest edition of the National Electric Code (NEC), ANSI/National Fire Protection Association (NFPA) 70, unless local code requirements indicate otherwise.

The heater comes factory-wired intended for use with 240 Volt, 60 Hz AC field electrical supply. To use 120 Volt, 60 Hz AC requires changing the position of the voltage selector board on the power distribution board. This must be done by a certified electrician only, as with all wiring. Be sure that the power source to the heater is turned off or disconnected before servicing.

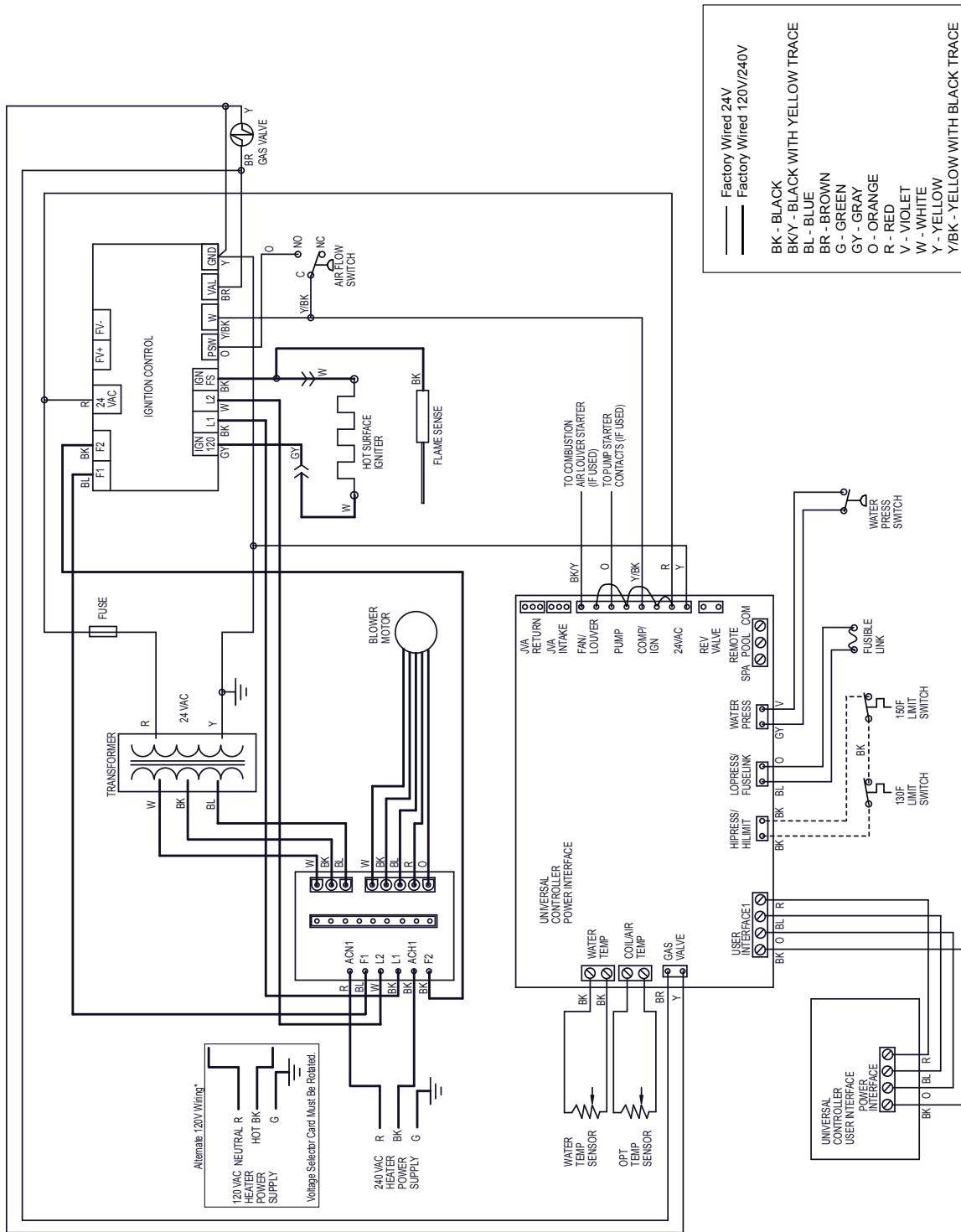

NOTES: IF ANY OF THE ORIGINAL WIRE AS SUPPLIED WITH THE HEATER MUST BE REPLACED, APPLIANCE WIRING MATERIAL RATED FOR 105°C MUST BE USED. WHERE MARKED THUS - - - - - APPLIANCE WIRING MATERIAL RATED FOR 200°C MUST BE USED. * See Section 6.2. for Complete Details.

SI L'UN QUELCONQUE DES FILS D'ORIGINE FOURNIS AVEC LE CHAUFFE-EAU DOIT ÊTRE REMPLACÉ, UN FIL POUR APPARELS ÉLECTRIQUES À TOLÉRANCE NOMINALE DE 105°C DOIT ÊTRE EMPLOYÉ. SI LE FIL PORTE LE SYMBOLE - - - - - LE REMPLACER UNIQUEMENT PAR UN FIL POUR APPARELS ÉLECTRIQUES À TOLÉRANCE NOMINALE DE 200°C.

H0287800H

Figure 20. LXi Connections/Schematic Wiring Diagram

NOTE If the heater is converted to accept 120V, the “Hot” wire of the 120V power supply has to be connected to the black wire (ACH1) on the power distribution board and the “Neutral” wire of the 120V power supply has to be connected to red wire (ACN1) of the power distribution board.

To wire the LXi heater to a 120V or 240V/60 Hertz (Hz) electrical source:

1. Remove the door of the heater.
2. Connect the wires from the power source to the leads on the right side of the heater in the space behind the raceway. See Figure 21.

NOTE No external junction box is required.

6.2.1 Converting the Heater for a 120V Power Source

To convert the LXi heater to 120 Volt, 60 Hz AC requires reversal of the voltage selector board on the power distribution board. The following procedure should be performed **before** the heater is connected to a power source:

1. Identify the power distribution board on the heater. It is located to the right of the ignition control on the raceway. See Figure 22.
2. Cut the plastic wire tie that is holding the voltage selector board in place and discard the wire tie. Unplug the voltage selector board from the receptacle. See Figure 23.
3. Rotate the voltage selector board 180° and reinsert it into the receptacle so that the hole in the board is not visible. Be sure that the board is securely seated in the receptacle.

NOTE The voltage selector board is keyed so that it will fit in only one (1) direction for either selected voltage (either side of the board).

6.3 Bonding

⚠ CAUTION

To prevent premature failure of the appliance resulting from stray voltages and voltage differentials, the heater must be bonded to other equipment which is part of the pool plumbing system with a solid copper wire not smaller in diameter than 8 AWG (6 AWG in Canada).

⚠ ATTENTION

Pour éviter le bris prématuré de l'appareil dû à des tensions vagabondes et à des différences de tension, le chauffe-piscine doit être scellé à l'équipement faisant partie de la plomberie de la piscine à l'aide d'un fil de cuivre massif dont le diamètre n'est pas inférieur à un calibre 8 (un calibre 6 dans Canada).

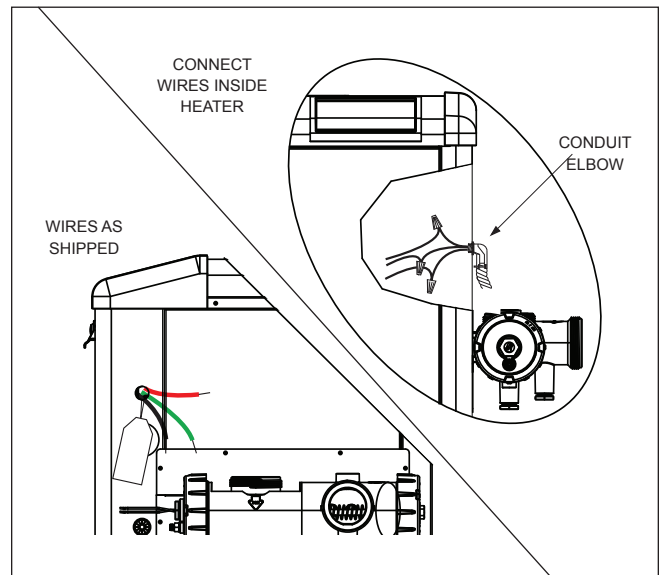

Figure 21. Field Wiring Connections

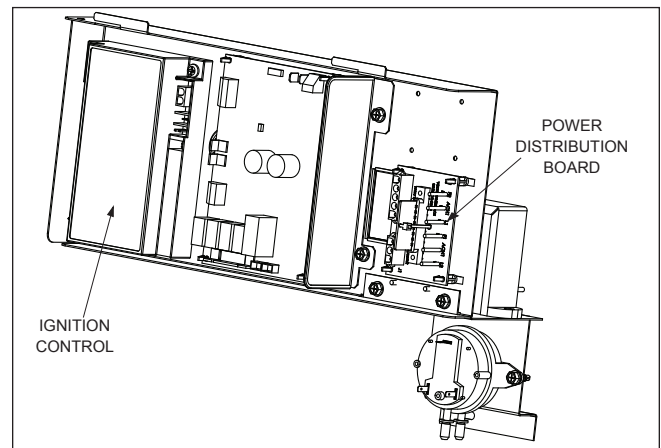

Figure 22. Location Of Power Distribution Board

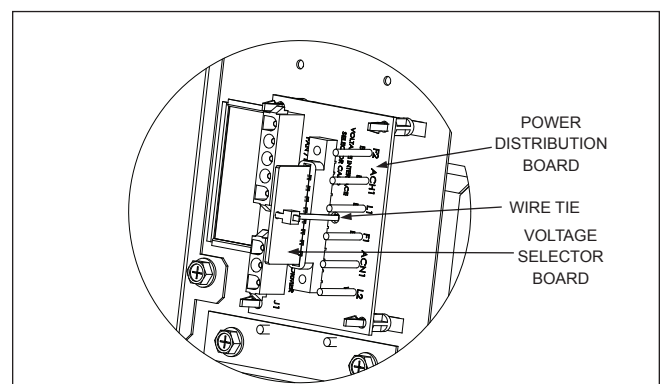

Figure 23. Power Distribution Board With Voltage Selector Board Installed for 240 VAC

Zodiac Pool Systems, Inc., requires that the appliance be connected to a “bonding loop” that includes all electrical equipment in the system and on the equipment pad. Bonding lugs must be connected with a solid copper wire not smaller than 8 AWG (6 AWG in Canada). Failure to do so will void the Zodiac Pool Systems, Inc. warranty.

Additionally, in the United States the National Electrical Code (NEC) and in Canada the Canadian Electrical Code (CEC), require that all metallic components of a pool structure, including reinforcing steel, metal fittings and above ground components be bonded together (forming an “equipotential bonding grid”) with a solid copper conductor not smaller than an 8 AWG (6 AWG in Canada).

The NEC and CEC also require that the equipment and/or appliances associated with the pool water circulating system, including, but not limited to, pump motors and heaters, be bonded together as part of the equipotential bonding grid. Zodiac Pool Systems, Inc. provides a special labeled bonding lug on the right side of the heater to accommodate this requirement.

6.4 Optional Pump Connection (Maintain Temp Feature)

This optional feature allows the heater to turn on the pool pump, bypassing the time clock setting, to maintain the desired temperature. In order for the MAINTAIN TEMP feature to be functional, a relay

must be installed and a dedicated line from the pool pump time clock to the Maintain Temp (Pump) Relay is needed. See Figure 24. The relay and pertinent instructions can be obtained by ordering Zodiac Pool Systems, Inc. part number R0467200.

6.5 Optional Remote Controls

⚠ WARNING

RISK OF ELECTRIC SHOCK WHICH CAN RESULT IN SERIOUS INJURY OR DEATH. Before attempting installation or service, ensure that all power to the device is disconnected/turned off at the circuit breaker.

⚠ AVERTISSEMENT

RISQUE DE CHOC ÉLECTRIQUE POUVANT CAUSER DES BLESSURES GRAVES OU LA MORT. Avant de tenter l'installation ou d'utiliser le service, assurez-vous que l'alimentation allant vers le dispositif soit débranchée/éteinte au niveau du disjoncteur du circuit. Branchez seulement à un circuit protégé par un disjoncteur de mise à la terre.

Electrical wiring must be in accordance with the latest edition of the National Electric Code (NEC), ANSI/National Fire Protection Association (NFPA) 70, unless local code requirements indicate otherwise.

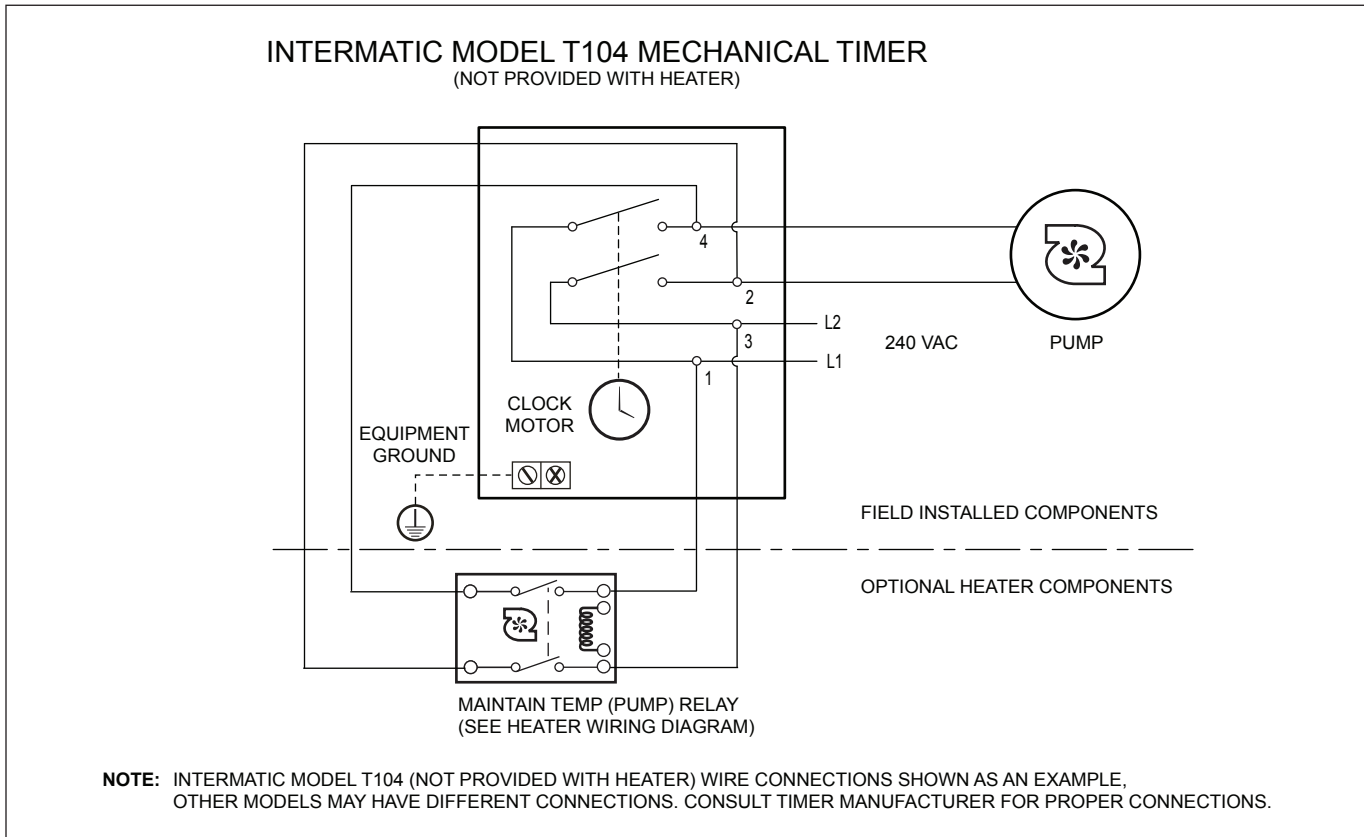

Figure 24. Example of Maintain Temp Wiring to the Time Clock

6.5.1 Connection to a Remote Pool-Off-Spa Selector (3-Wire Connection)

6.5.1.1 Install the Remote Pool-Off-Spa Selector

1. Turn off the power to both the pool/spa control system and the heater unit.
2. Remove the front panel door from the front of the heater to access the raceway.
3. Run the wires from the pool/spa control system through the opening, located on the lower right or left hand side of the heater.
4. Connect the wiring from the pool/spa control system to the heater remote control terminal. See Figure 25.

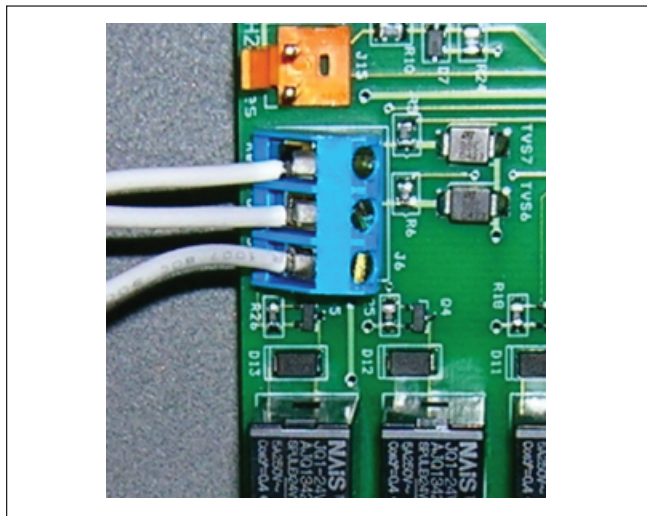

Figure 25. Remote Pool-Off-Spa Connection (3-Wire Connection)

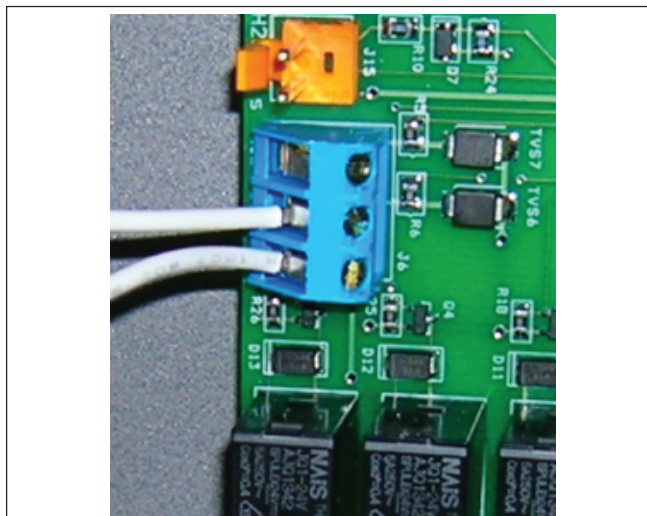

Figure 26. AquaLink® RS or Remote TSTAT Connection (2-Wire Connection)

5. Restore power to the heater and the pool/spa control system.

6.5.1.2 Configure the Control Panel

1. Make sure the control is in the **OFF** mode.
2. To enter the Service Setup mode, press and hold the **MENU**, **POOL**, and **SPA** buttons for 5 seconds.

NOTE The display will revert back to OFF after 1 minute since the last key press.

3. Press the Up or Down button to display **RE-MOTE**. Press the **MENU** button. The **SELECT REMOTE OFF** (default remote) appears. Use the Up or Down button to scroll through the Remote options. When you reach **HI-LO-COM**, press the **MENU** button to select the remote. Press **POOL** or **SPA** to exit Service Setup mode.

6.5.2 Connection to an AquaLink RS Control System or Remote TSTAT (2-Wire Connection)

An interrupt (on/off) type remote can be connected as a Remote TSTAT, as described in this section. This type of remote control will turn the heater on or off, but will not perform any other function.

This type of connection may be used to connect a Jandy AquaLink RS Control System using any revision level programmed control chip. The control will automatically turn the heater on and off and will display the pool water temperature, but all other functionality and display information will be inactive. When using this type of connection, remember to set the LXi heater's control to "SPA" and set the thermostat control to maximum.

Consult with the Zodiac Pool Systems, Inc. Technical Support Department, 800.822.7933, for questions about installing non-Jandy remote controls.

6.5.2.1 Install the Remote TSTAT

1. Turn off the power to both the pool/spa control system and the heater unit.
2. Remove the front panel door from the front of the heater to access the raceway.
3. Run the wires from the pool/spa control system through the opening, located on the lower right or left hand side of the heater.
4. Connect the wiring from the pool/spa control system to the heater remote control terminal. See Figure 26.
5. Restore power to the heater and the pool/spa control system.

NOTE If you install a time clock to control the filter pump operation, it is recommended that the time clock have its own low voltage (Fireman’s) switch to turn off the heater before turning off the pump. The switch should shut off the heater about 15 minutes before the filter pump shuts off. This will allow for a more efficient pump operation by removing any residual heat contained in the heat exchanger back to the pool.

⚠ CAUTION

To avoid damage to the heater, **do not connect the power supply of the heater to the output side of the clock** if your time clock simply interrupts the high voltage power supply or has a high voltage output. Doing so will prevent the blower from purging the residual heat from the heater when the heater turns off. The blower must be allowed to run for 45 seconds after the heater shuts off.

6.5.2.2 Configure the Control Panel

1. Make sure the control is in the **OFF** mode.
2. To enter the Service Setup mode, press and hold the **MENU**, **POOL**, and **SPA** buttons for 5 seconds.

NOTE The display will revert back to OFF after 1 minute since the last key press.

3. Press the Up or Down button to display **RE-MOTE**. The **SELECT REMOTE OFF** (default remote) appears. Use the Up or Down button to scroll through the Remote options. When you reach **REMOTE TSTAT**, press the **MENU** button to select the remote. Press **POOL** or **SPA** to exit the Service Setup mode.

4. Press **SPA**. Adjust the setpoint to the maximum setting of 104 °F.

6.5.2.3 Remote Operation

The LXi pool/spa heater controls can be wired for remote operation. All Jandy AquaLink® RS Control Systems will permit the heater to be operated by remote control.

If you are setting up a new pool or spa system, call your local Jandy distributor or Zodiac Pool Systems, Inc, 800.822.7933, for information on the correct RS Control System to meet your needs.

To provide “smart” communication between the LXi and an AquaLink RS PCB Board through a red four-pin RS485 connector, your PCB firmware must be Rev N or higher, as shown in Figure 28. To determine the REV of the PCB firmware in your system, refer to Table 7 and Figures 27 and 28.

If your PCB firmware is REV MMM or lower, as

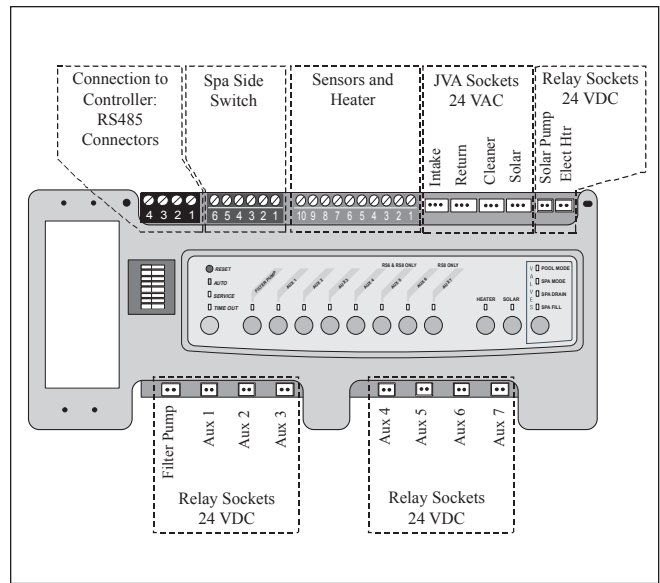

Figure 27. PCB Board with Firmware REV MMM or Lower

shown in Figure 27, connect the heater to the control as indicated in Section 6.5.2.

If your PCB firmware is REV N or higher, as shown in Figure 28, continue to follow the procedures in this section.

Table 7. PCB Boards with Firmware REV MMM & REV N

Components	REV MMM	REV N
RS485 Connectors	One (1) set of four (4)	Two (2) sets of four (4)
JVA Sockets 24 VAC	Located on top of board	Located on bottom of board
Relay Sockets 24 VDC	10 total sockets. Eight (8) located on bottom, two (2) on top of board	11 total sockets. All located on bottom of board.

Do not connect more than two wires to any of the

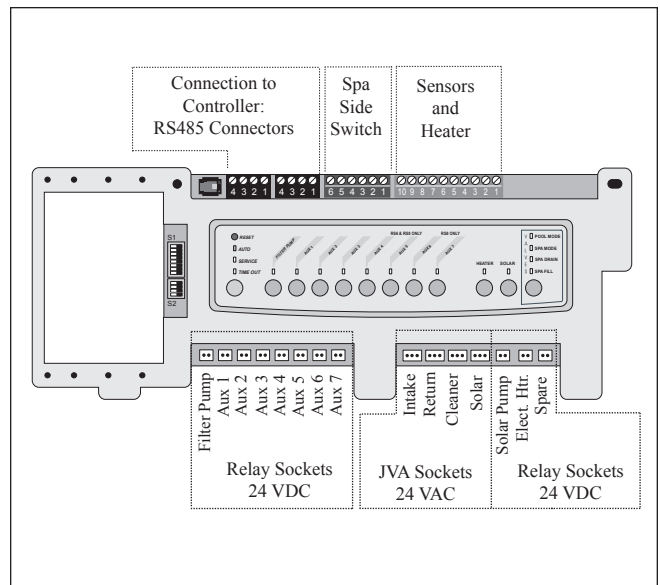

Figure 28. PCB Board with Firmware REV N or Higher

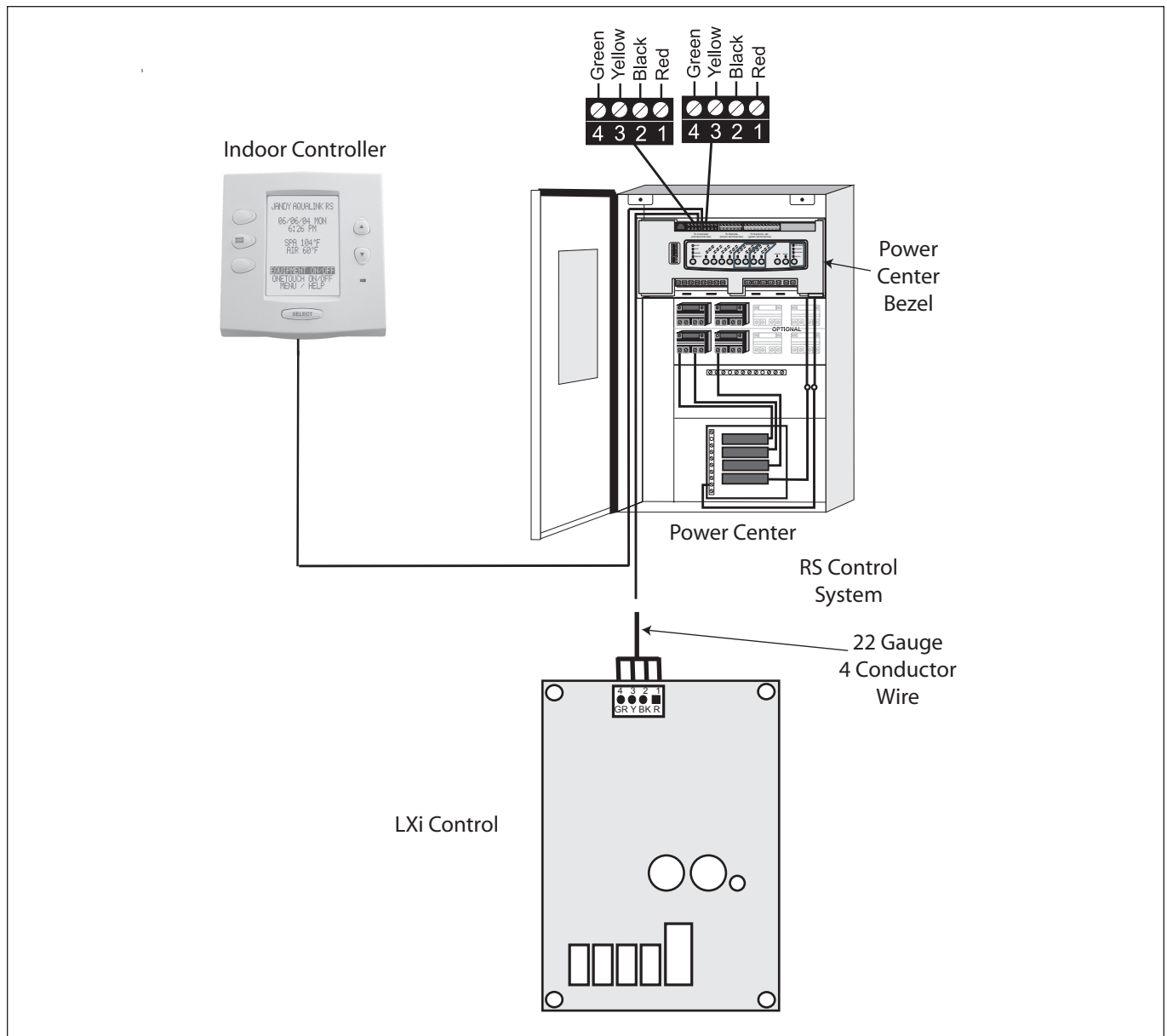

Figure 29. Wiring an LXi to a Jandy RS Remote

terminals in the RS Control System when connecting peripheral devices. If connecting the LXi heater to the RS Control System creates this situation, then a Multiplexing PCB kit must be used. Call your distributor or Zodiac Pool Systems, Inc., to order the kit.

To connect the LXi to your RS control system, refer to Figure 29 and follow the steps listed below.

1. Turn off the power to both the heater and the RS control.
2. Open the RS Power Center enclosure and remove the front dead panel.

NOTE Only an RS System with firmware revision "N", or higher, will support the LXi heater interface. Refer to Table 7 and Figures 27 and 28 to determine the REV of your system's firmware. If it is "N" or higher, continue with these procedures. If it is MMM or lower, follow the procedures in *Section 6.5.2*.

NOTE Only a PDA System with firmware revision 4.1, or higher, will support the LXi heater interface.

3. Use 22 gauge 4-conductor wire (Jandy part # 4278) to run between the heater and the RS control, and match the wire color order.
4. The wires coming from the LXi heater can be "doubled up" on the red terminal bar with the four (4) wires coming from the indoor controller.

NOTE If you need to install more than two (2) wires in each terminal, order a Jandy Multiplex PCB Kit, which includes the Multiplex Board (Zodiac part # 6584). Never put more than two (2) wires into each of the pins of the terminal bar.

5. Check all wiring, then apply power to both the heater and the RS control system. Operation can be verified in either Service or Auto mode. See your RS Control System manual for instructions about operation.

When the LXi heater is first powered on and there is an RS control connected to the heater, the display on the heater control will show "JANDY REMOTE ONLINE PUSH MENU TO DISABLE".

When the LXi heater is online with the RS control, all functionality of the control on the heater is disabled. The heater functions can be controlled only at the RS unit.

To temporarily use the heater controls, press the MENU button. The message "JANDY REMOTE ONLINE PUSH MENU TO DISABLE" will disappear from the heater display. All functionality has now been returned to the control on the heater. In this mode the RS unit is no longer controlling the heater.

To return the functionality to the RS unit, cycle (turn off and then turn on) the power to the heater, or press the MENU button for 5 seconds to enter the User Setup Mode and then enable the Jandy Remote.

6.5.3 Connection to a Secondary User Interface

The LXi pool/spa heater can also be controlled remotely by installing a second wall mountable User Interface. Please order Zodiac® part number R0467500. This kit contains the second User Interface, wall mounting backplate, and necessary hardware.

WARNING

To prevent an unsafe condition which can result in property damage, severe injury, or death, do not disable or remove the control from the heater.

AVERTISSEMENT

Pour prévenir une condition dangereuse qui peut entraîner des dommages matériels, des blessures graves, voire la mort, ne désactivez pas ou ne retirez pas la commande de l'appareil de chauffage.

Section 7. Operating Instructions

7.1 Normal Operation

The LXi heater is capable of automatic operation based on a call for heat at preset temperatures and an operator selection between pool or spa settings. Additionally, the heater may be controlled by a remote unit to anticipate bather load, changes in temperature settings, or a variety of other demands that might be encountered. The heater has an internal safety system which allows operation in a variety of conditions and prevents operation when certain adverse conditions are encountered. The heater is capable of diagnosing problems within the safety controls scheme, enabling faster service and less down time in the event of a failure.

When the heater is powered, water is flowing through the heater, and the temperature of the water entering the heater is below the temperature control setting, an operating cycle is initiated by the automatic control. The combustion blower is started. If the blower pressure switch senses adequate airflow, the ignition sequence starts. First, a 15 second pre-purge takes place. Next, the igniter is energized. After 40 seconds of igniter heat-up time the gas valve is opened (approximately 1 minute after the call for heat). If flame is sensed at the burner within 7 seconds, operation continues. Operation will continue until the temperature of the water entering the heater reaches the temperature control setting.

If ignition is unsuccessful, or if the flame fails during normal operation, the ignition control shuts off the gas valve. It imposes a post purge, initiates additional ignition cycles, and shuts down the system if ignition is not achieved in three (3) cycles. After 1 hour, the system will restart and try again.

To reset the LXi heater to provide three (3) additional attempts without waiting an hour, turn off the control and then put it back in either the Pool or Spa mode.

7.2 Start-Up

WARNING

For your safety, when starting the heater, keep your head and face well away from the burner area to prevent any risk of personal injury.

AVERTISSEMENT

Pour votre sécurité personnelle lorsque vous mettez l'appareil en marche, tenez votre tête et votre visage loin du brûleur pour éviter tout risque de blessure.

⚠ WARNING
Vent pipes and heater tops get hot! These surfaces can cause serious burns. Do not touch these surfaces while the heater is in operation.
⚠ AVERTISSEMENT
Les tuyaux d'aération et le dessus de l'appareil deviennent chauds! Ils peuvent causer de graves brûlures. Ne touchez pas à ces surfaces lorsque l'appareil est en marche.
⚠ CAUTION
Do not use this heater if any part has been under water. Immediately call a qualified service technician to inspect the heater and replace any part of the control system and any gas control which has been under water.
⚠ ATTENTION
N'utilisez pas cet appareil s'il a été plongé dans l'eau, même partiellement. Faites inspecter l'appareil par un technicien qualifié et remplacez toute partie du système de contrôle et toute commande qui ont été plongés dans l'eau.
⚠ CAUTION
Should overheating occur or the gas supply fail to shut off, turn off the manual gas control valve to the heater.
⚠ ATTENTION
En cas de surchauffe ou si l'alimentation en gaz ne s'arrête pas, fermez manuellement le robinet d'arrêt de l'admission de gaz.
⚠ CAUTION
Do not attempt repairs on the gas controls or appliance. Tampering is dangerous and voids all warranties.
⚠ ATTENTION
Ne tentez pas d'effectuer des réparations au système de régulation du débit du gaz ou à l'appareil. Toute modification non autorisée est dangereuse et entraîne l'annulation de toutes les garanties.
⚠ CAUTION
Keep all objects off the top of the heater. Blocking air flow could damage the heater and might void the warranty.
⚠ ATTENTION
Ne posez aucun objet sur le dessus de l'appareil. Il pourrait empêcher la circulation de l'air, ce qui risquerait d'endommager l'appareil et d'annuler la garantie.

Be sure that there is water in the pool and that the surface level is above the skimmer or other inlet of the pool's filter system.

Confirm that pool water is flowing normally through the pool system and equipment. With any new pool or spa installation, operate the filter pump with the heater off long enough to completely clean the water. This will remove any installation residue from the water. Clean the filter at the end of this operation before starting the heater. Start the heater in accordance with the Operating Instructions section of this manual, with particular attention to the lighting and shutdown instructions and temperature control operation.

The heater may not start on the first try. Air in the gas line or other start-up situations may cause it to cycle. It will lock out if ignition is not achieved in three (3) attempts. (See *Section 9.2, Service Codes.*) To reset the LXi heater to provide three (3) additional attempts, turn off the control and then put it back in either the Pool or Spa mode.

When the heater starts, immediately feel the outlet header of the heater to confirm that there is adequate water flow. The header should not be hot. Normally, water temperature will rise only a few degrees as it passes through the heater, and a "hot" header or pipe indicates low water flow.

⚠ WARNING
When the heater is fired for the first time, the combustion chamber refractory binder material is driven out by the heat of the flame. White smoke and/or sharp odors may be emitted from the vent during this period. Do not inhale combustion product fumes at any time, and especially when these fumes are being emitted. This "burn-in" period will last only a few minutes.

⚠ AVERTISSEMENT
Lorsque l'appareil est mis en marche pour la première fois, le matériau liant réfractaire de la chambre de combustion est expulsé par la chaleur de la flamme. De la fumée blanche et de fortes odeurs peuvent se dégager du tuyau d'aération à ce moment-là. N'inhalez les fumées de combustion à aucun moment, surtout au moment où elles sont émises. Cette période de combustion ne durera que quelques minutes.

When raising the temperature of a cold pool, program the time clock to turn the pump off 23 hours after the start time. For example, if the start time is 2:00 PM, then set the stop time at 1:00 PM. This lets the filter system and heater operate continuously until the water reaches the temperature setting on the temperature control. When that happens, the heater will automatically shut off, but the filter pump will keep running.

7.3 Operating the Controller

Your new LXi Pool Heater is controlled by an ad-

vanced microprocessor based controller that provides a sophisticated yet simple interface to operate your heater for maximum efficiency and enjoyment of your pool. To locate the control buttons, see Figure 28.

7.3.1 Off Mode

When the control panel is turned off, the screen displays **GAS HEATER IS OFF PRESS POOL OR SPA**.

7.3.2 Pool Mode - (Normal Heat)

To enable the pool mode, press **POOL**. The associated left green LED indicator will light and the unit will display **SET:XXX°**.

NOTE *XXX* represents the current temperature setting on the control. The default setting for pool temperature is 80°F (26°C).

You can change the temperature set point by pressing the **Up** or **Down** button. Repeatedly press the **Up** or **Down** button until you reach the desired temperature set point. After 5 seconds of inactivity, the new set point is stored in memory.

When the water temperature falls to 1° below the temperature setting, the control will start the heater and the associated right LED will light RED.

7.3.3 Pool Mode - (Optional Maintain Heat)

If connected, the Maintain Heat mode allows the heater to monitor the temperature of the water 24 hours a day by turning the pool pump on and sampling the water temperature. When the water temperature drops below the programmed temperature set point, the control will start the heater.

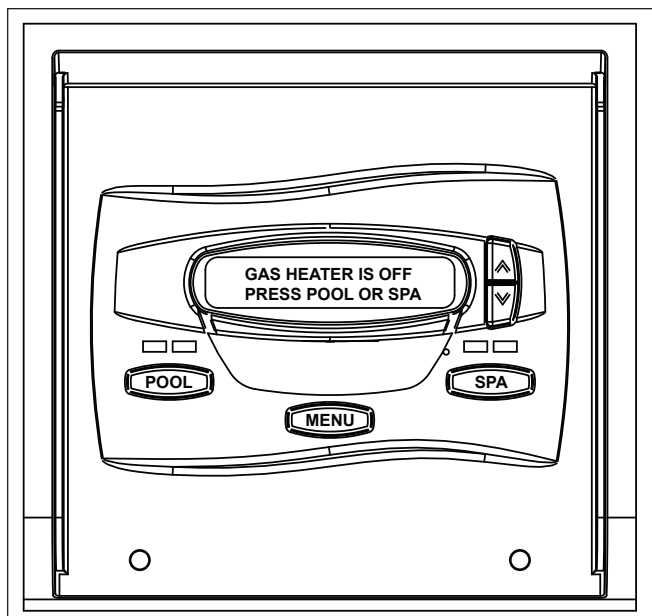

Figure 28. Main Control Panel

To operate in pool mode with the Maintain Heat feature, press **POOL**, then press **MENU**, press the **Down** button until **MAINTAIN POOL HEAT** is displayed, press the **MENU** button.

The associated left green LED indicator will light and the unit will display **SET:XXX°**. Change the temperature set point by pressing the **Up** or **Down** button until the desired set point is displayed. After 5 seconds of inactivity, the new set point is stored in memory.

7.3.4 Spa Mode - (Normal Heat)

To enable the spa mode, press **SPA**. The associated left green LED indicator will light and the unit will display **SET:XXX°**.

NOTE *XXX* represents the current temperature setting on the control. The default setting for spa temperature is 102°F (38°C).

You can change the temperature set point by pressing the **Up** or **Down** button. Repeatedly press the **Up** or **Down** button until you reach the desired temperature set point. After 5 seconds of inactivity, the new set point is stored in memory. When the water temperature falls to 1° below the temperature setting, the control will start the heater and the associated right LED will light RED.

7.3.5 Spa Mode - (Optional Maintain Heat)

If connected, the Maintain Heat mode allows the heater to monitor the temperature of the water 24 hours a day.

When the water temperature drops below the programmed temperature set point, the control will start the heater.

To operate in spa mode with the Maintain Heat feature, press **SPA**, then press **MENU**, press the **Down** button until **MAINTAIN SPA HEAT** is displayed, press the **MENU** button. The associated left green LED indicator will light and the unit will display **SET:XXX°**. Change the temperature set point by pressing the **Up** or **Down** button until the desired set point is displayed. After 5 seconds of inactivity, the new set point is stored in memory.

7.4 User Setup Options

The User Setup options allow the user to select specific Languages, Temperature Scale, Spa Timer, and Display Light options.

7.4.1 Language Setup

1. Make sure the control is in the **OFF** mode.
2. To enter the User Setup mode, press and hold the **MENU** button for 5 seconds.

NOTE The display will revert back to **OFF** after one minute since the last key press.

- To select a language, use the **Up** or **Down** button to display **SELECT USER SETUP LANGUAGE**. Press the **MENU** button. The **SELECT LANGUAGE ENGLISH** (default language) appears, use the **Up** or **Down** button to scroll through the language options. When you reach the desired language, press the **MENU** button to select the language. Press **POOL** or **SPA** to exit the User Setup mode.

7.4.2 Temperature Scale Setup

- Make sure the control is in the **OFF** mode.
- To enter the User Setup mode, press and hold the **MENU** button for 5 seconds.
- To select temperature scale, use the **Up** or **Down** button to scroll through to display **SELECT USER SETUP TEMPERATURE SCALE**. Press the **MENU** button. The **SELECT TEMP SCALE °F:** (default temperature scale) appears, use the **Up** or **Down** button to scroll to display **SELECT TEMP SCALE °C:**. When you reach the desired temp scale, press the **MENU** button to select. Press **POOL** or **SPA** to exit the User Setup mode.

7.4.3 Spa Timer Setup

- Make sure the control is in the **OFF** mode.
- To enter the User Setup mode, press and hold the **MENU** button for 5 seconds.
- To select spa timer, use the **Up** or **Down** button to scroll through to display **SELECT USER SETUP SPA TIMER**. Press the **MENU** button. The **SELECT SPA TIMER CONTINUOUS:** (default spa timer setting) is displayed. To turn the spa on or off indefinitely, press the **MENU** button to select.
- To select the length of time for the spa to run, use the **Up** or **Down** button to scroll to display **SELECT SPA TIMER TIME SELECTION**. Press the **MENU** button to select. The display **SELECT SPA TIME 01:00 HRS:** (default time setting) is displayed. Use the **Up** or **Down** button to select the length of time for the spa to run (between 00:15 to 23:00 hours in increments of 00:15 minutes). Press the **MENU** button to select how long the spa will run. Press **POOL** or **SPA** to exit the User Setup mode.

7.4.4 Display Light Setup

- Make sure the control is in the **OFF** mode.
- To enter the User Setup mode, press and hold the **MENU** button for 5 seconds.
- To select display light setup, use the **Up** or **Down** button to scroll through to display **SELECT USER SETUP DISPLAY LIGHT**. Press the **MENU** button. The **SELECT DISPLAY LIGHT 2 MIN TIMEOUT:** (default display light setting) is displayed. This option allows the display light to turn off after 2 minutes. Press the **MENU** button to select. Use the **Up** or **Down** button to scroll to display **SELECT DISPLAY LIGHT LIGHT OFF:**, this option allows the display light to turn off, press the **MENU** button to select. Use the **Up** or **Down** button to scroll to display **SELECT DISPLAY LIGHT LIGHT ON:**, this option allows the display light to turn on, press the **MENU** button to select. Press **POOL** or **SPA** to exit the User Setup mode.

7.5 Set Point Lockout

Make sure the control is in the **ON** mode (**POOL** or **SPA**), press and hold the **Up** and **Down** buttons for 5 seconds. The set point will be locked and the control will operate in the mode it was in when the Set Point Lockout occurred. If an attempt to change the set point is made while the control is in Set Point Lockout, the control will display **SET POINT LOCKED**. To unlock the Set Point Lockout, press and hold the **Up** and **Down** buttons for 5 seconds. The unit will display **SET POINT UNLOCKED**.

7.6 Lighting and Shutdown Procedures

WARNING

Do not attempt to light the heater with the door off. Doing so may cause severe bodily injury.

AVERTISSEMENT

Ne tentez pas d'allumer l'appareil sans que la porte soit en place. Vous pourriez être victime de blessures corporelles graves.

Before starting your heater, be sure that all of the functions and limits of the LXi controller has been set according to the previous sections of this manual. Once the control is set to your preferences, follow the instructions outlined below. Read and follow all safety instructions first. A more detailed set of lighting and shutdown instructions are listed on the label located on the inside of the heater door and in Figure 29.

FOR YOUR SAFETY READ BEFORE OPERATING

PRÉCAUTIONS À LIRE AVANT D'UTILISER

⚠WARNING: If you do not follow these instructions exactly, a fire or explosion may result, causing property damage, personal injury or loss of life.

⚠AVERTISSEMENT: Si vous ne suivez pas ces instructions à la lettre, il y a risque d'incendie ou d'explosion, pouvant entraîner des dégâts matériels et des blessures graves voire mortelles.

- A. This appliance does not have a pilot light. It is equipped with an ignition device which automatically lights the heater. Do NOT try to light the burners by hand.
- B. BEFORE OPERATING, smell all around the appliance area for gas. Be sure to smell next to the floor because some gas is heavier than air and will settle on the floor.
WHAT TO DO IF YOU SMELL GAS
 - Do not try to light any appliance
 - Do not touch any electric switch; do not use any phone in your building.
 - Immediately call your gas supplier from a neighbor's phone. Follow the gas supplier's instructions.
 - If you cannot reach your gas supplier, call the fire department.
- C. Use only your hand to push in or turn the gas control knob. Never use tools. If the knob will not push in or turn by hand, don't try to repair it, call a qualified service technician. Force or attempted repair may result in a fire or explosion.
- D. Do not use this appliance if any part has been under water. Immediately call a qualified service technician to inspect the appliance and to replace any part of the control system and any gas control which has been under water.

- A. Cet appareil ne possède pas de veilleuse. Il est équipé d'un dispositif qui allume automatiquement le chauffe-eau. Ne PAS essayer d'allumer les brûleurs à la main.
- B. AVANT DE METTRE EN MARCHÉ, humer pour s'assurer de l'absence de gaz autour de l'appareil. Sentir à proximité du sol car certains gaz sont plus lourds que l'air et ne s'élèvent pas.
MARCHE À SUIVRE EN CAS D'ODEUR DE GAZ
 - Ne pas tenter d'allumer aucun appareil.
 - Ne toucher à aucun interrupteur ; ne pas utiliser le téléphone dans le bâtiment.
 - Appeler immédiatement la compagnie de gaz en utilisant le téléphone d'un voisin. Suivre les instructions données par celle-ci.
 - Si l'on n'arrive pas à joindre la compagnie de gaz, appeler les pompiers.
- C. Enfoncer et tourner le bouton de commande du gaz à la main uniquement. Ne pas utiliser d'outil. Si le bouton résiste, ne pas essayer de le réparer ; appeler un réparateur qualifié. Une réparation forcée ou mal faite peut causer un incendie ou une explosion.
- D. Ne pas utiliser cet appareil si une de ses pièces a été sous l'eau. Appeler immédiatement un réparateur qualifié pour inspecter l'appareil et remplacer toute partie du circuit de commande et toute commande de gaz qui aurait subi des dégâts d'eau.

OPERATING INSTRUCTIONS

MODE D'EMPLOI

1. STOP! Read the safety information above on this label.
- 2.* Set the thermostat for POOL and SPA to 70°F(21°C), or the lowest possible setting and switch the controller mode to OFF.
3. Turn off all electric power to the appliance.
4. This appliance is equipped with an ignition device which automatically lights the heater. Do not try to light the burners by hand.
5. Remove the heater door.
6. Turn gas control knob clockwise ↻ to OFF.
7. Wait five (5) minutes to clear out any gas. Then smell for gas, including near the floor. If you smell gas, STOP! Follow "B" in the safety information above on this label. If you don't smell gas, go to next step.
8. Turn gas control knob counterclockwise ↺ to ON.
9. Replace control access panel
10. Turn on all electric power to appliance.
- 11.* Set thermostat to desired settings for "Pool and Spa" and switch the controller mode from OFF to either POOL or SPA.
12. If the appliance will not operate, check that the filter pump is on, the filter is clean and water is flowing to the pool. Otherwise, follow the instructions "To Turn Off Gas To Appliance" and call your service technician or gas supplier.

1. ARRÊT! Lire les informations de sécurité fournies ci-dessus.
- 2.* Régler le thermostat pour PISCINE et SPA à 70°F (21°C), ou le plus bas arrangement, et commutez le contrôleur à ARRÊT.
3. Couper toute arrivée de courant de l'appareil.
4. Cet appareil est équipé d'un dispositif qui allume automatiquement le chauffe-eau. Ne pas essayer d'allumer les brûleurs à la main.
5. Retirer la porte du chauffe-eau.
6. Tourner le bouton de commande du gaz dans le sens horaire ↻ jusqu'à ARRÊT.
7. Attendre cinq (5) minutes que le gaz se soit dissipé. Puis humer pour s'assurer de l'absence de gaz, en particulier au niveau du sol. Si cela sent le gaz, ARRÊTER tout de suite ! Suivre les précautions de la partie "B" ci-dessus. S'il n'y a pas d'odeur de gaz, passer à l'étape suivante.
8. Tourner le bouton de commande du gaz dans le sens anti-horaire ↺ jusqu'à ON.
9. Remettre le panneau d'accès aux commandes.
10. Remettre l'appareil électrique sous tension.
- 11.* Régler le thermostat aux réglages désirés pour PISCINE et SPA et commutez le contrôleur de ARRÊT, à soit PISCINE ou SPA.
12. Si l'appareil électrique ne fonctionne pas, s'assurer que la pompe à filtre est allumée, que le filtre est propre et que la piscine est alimentée en eau. Sinon, suivre les instructions de "Coupeure de l'arrivée de gaz de l'appareil" et appeler le réparateur ou la compagnie de gaz.

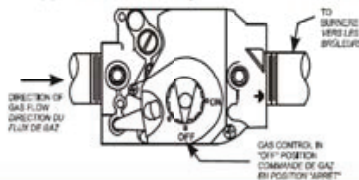

TO TURN OFF GAS TO APPLIANCE

COUPURE DE L'ARRIVÉE DE GAZ DE L'APPAREIL

- 1.* Set the thermostat for POOL and SPA to 70°F(21°C) or the lowest possible setting and switch the controller mode to OFF.
2. Turn off all electric power to the appliance if service is to be performed.
3. Turn gas control knob clockwise ↻ to OFF.
4. Replace control access panel.

- 1.* Régler le thermostat pour PISCINE et SPA à 70°F (21°C), ou le plus bas arrangement, et commutez le contrôleur à ARRÊT.
2. Couper toute arrivée de courant de l'appareil s'il doit subir une réparation.
3. Tourner le bouton de commande du gaz dans le sens horaire ↻ jusqu'à OFF.
4. Remettre le panneau d'accès aux commandes.

See manual for details of operation of thermostat control.

H0208200F

*Voir le manuel pour les détails concernant l'opération du contrôle de thermostat.

Figure 29. Lighting and Shutdown Instructions

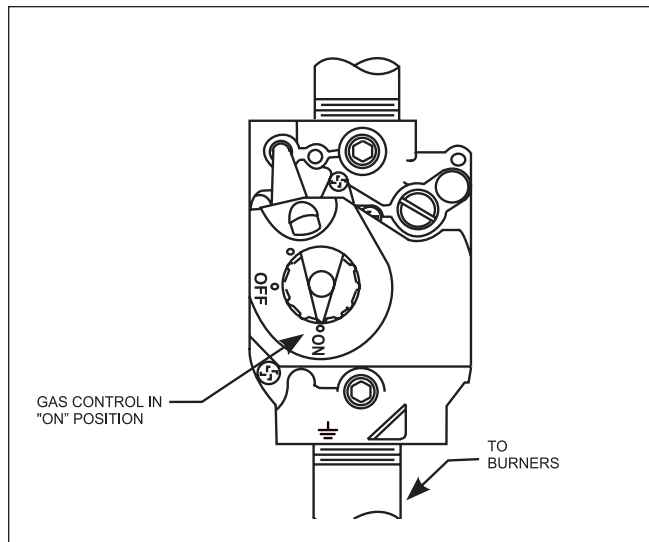

Figure 30. Gas Valve

7.6.1 Lighting the Heater

Lighting instructions are as follows:

1. Turn off all electrical power to the heater at the main junction box.
2. Remove the heater door and turn the heater gas valve to OFF.
3. Wait 5 minutes before trying to start the heater.
4. Turn the gas valve control knob counterclockwise to ON. See Figure 30.
5. Replace the heater door.
6. Turn on electrical power to the heater.
7. Turn on the filter pump.
8. Set the heater control to the "SPA" mode. If the temperature of the water exceeds the thermostat setting it is necessary to increase the thermostat setting to exceed the water temperature. Adjust the thermostat setting (desired temperature) to be greater than the water temperature. The igniter lights the burner when the thermostat calls for heat.
9. Set the time clock, if one is installed.

7.6.2 Shutdown

Complete shutdown instructions are as follows:

1. Set both temperature controls to their lowest setting.
2. Turn off the control. Make sure the display shows that the heater is off.

3. Turn off all electrical power to the heater at the junction box.
4. Open the heater door and turn the gas valve knob clockwise to off.
5. Shut off the external gas supply valve to the heater.

7.7 Adjusting the Water Pressure Switch

⚠ CAUTION

The water pressure switch should be adjusted to turn the heater off when the pump is off. Setting the switch to close at too low of a flow can damage the appliance. Adjust the switch to turn the heater off, not on.

⚠ ATTENTION

Le manoccontact de pression d'eau doit être réglé de façon à ce que l'appareil cesse de fonctionner si la pompe s'arrête. Si le manoccontact est réglé pour se fermer lorsque le débit d'eau est trop faible, l'appareil risque de s'endommager. Réglez le manoccontact pour qu'il arrête l'appareil, et non pour qu'il le mette en marche.

The pressure switch is preset at the factory for activation at 2 psi (14 kPa). Do not adjust the pressure switch if the heater is installed more than 15 feet (4.57 m) below the pool surface. Consult your local Jandy representative for recommendations.

On some installations, the piping from the heater to the pool is very short. The back pressure could be too low to trigger the pressure switch. If this happens, it may be necessary to install a directional fitting or elbows where the return line enters the pool. This will increase back pressure enough for the heater to operate properly.

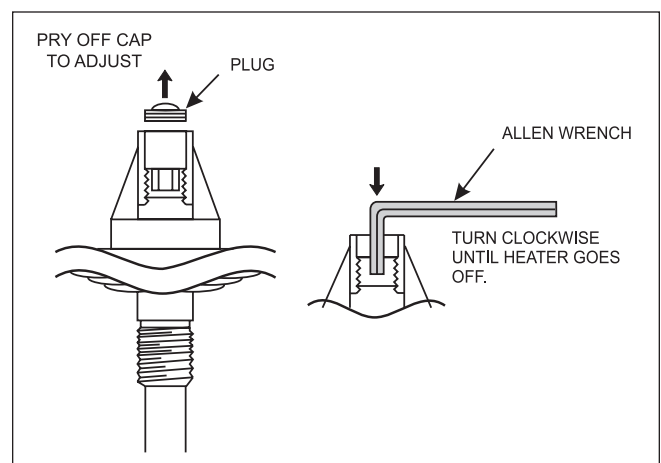

Figure 31. Adjustment of Pressure Switch

Make sure the pool filter is clean before making any pressure switch adjustment. A dirty filter will restrict the water flow and the pressure switch cannot be adjusted properly.

To adjust the pressure switch, refer to Figure 31 and proceed as follows:

1. Set the heater control to the "OFF" mode.
2. Remove the side panel above the front header to access the water pressure switch.
3. Start the filter pump and confirm by means of a voltmeter that the pressure switch closes (if the switch fails to close, replace it with a switch that has a lower minimum setting).
4. Set the heater control to either **POOL** or **SPA**. Heater should start.
5. Pry out the top cap on the pressure switch.
6. Use a 7/32 inch Allen wrench to turn the adjustment screw very slowly clockwise until the heater goes off.
7. Slowly turn the pressure switch adjustment screw **counterclockwise** one-quarter turn. The heater should come back on.
8. Check the adjustment by turning the filter pump OFF. The heater fan will continue to run but the burners should shut off immediately. If they do not, restart the filter pump and repeat Steps 6 and 7. Check the adjustment again.
9. Return the pool temperature control to the desired temperature.

It may be necessary to repeat these steps to get a proper setting. The switch must be set so that the heater will not fire unless the pump is running. If a proper setting cannot be reached, contact the factory service department.

7.8 Temperature Rise

The LXi pool and spa heaters have an internal bypass which accommodates a wide range of water flow. The bypass is easily adjustable to change the temperature rise for optimum performance and length of heater life. The bypass assures constant heat exchanger flow even though flow through the filter system will vary depending on how dirty the filter is.

For most installations, an external bypass valve is not needed in the heater water piping. This is due to the large size of the heater's internal bypass valve. If the pump flow rate is known to exceed 125 gpm (7.9 l/s), an external bypass may be needed to assure proper heater operation.

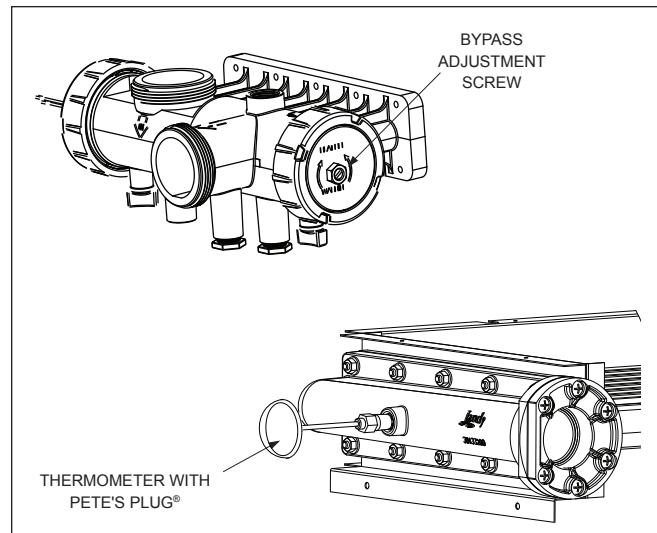

Figure 32. Temperature Rise Measurement

Water flow should be confirmed upon start-up of the heater and in most servicing situations. If the flow is not normal, corrections must be made to the pool system. Flow is evaluated by determining the water temperature rise through the heat exchanger.

Before checking the temperature rise, make sure that the pool filter is clean and that gas supply and manifold pressures are correct. If necessary, clean all components of the filter system. Temperature rise is measured in the return header of the LXi. To measure the temperature rise, turn off the filter pump and remove the plastic plug protruding through the cabinet on the return header side of the heater. (See Figure 32.) With the plug removed, install the special thread adapter and Pete's Plug® fitting and insert a pocket thermometer. A temperature rise measurement kit is available through your Jandy distributor. See *Section 11* of this manual for the correct kit number.

The internal bypass can be adjusted by means of a screw on the right-hand side of the header. To adjust the temperature rise to within the ranges specified in Table 7, proceed as follows:

1. If the piping system has an external bypass valve, close it.
2. Set the heater's control panel to the "OFF" position.
3. Start the filter pump.
4. After three minutes, note and record the thermometer reading. This is the pool water temperature.
5. Start the heater by setting the control panel to either **POOL** or **SPA**. Allow the heater to operate for 5 minutes or more. Note and record the thermometer reading. Subtract pool water temperature from this reading. This difference

is the temperature rise. Refer to Table 7. If your measured temperature rise is within the range designated for your heater, skip steps 6 through 8.

6. Locate the bypass adjustment screw on the right-hand side of the header. (See Figure 33.) Loosen the nut so that the screw can be adjusted. A slight water leak past the nut may be expected. Turn the screw counterclockwise to decrease the temperature rise, and clockwise to increase the temperature rise as needed to achieve the ranges in Table 7. After the adjustment, tighten the nut so that no leaks occur.
7. If the temperature rise is too low and cannot be raised by means of the adjustment screw, the flow is in excess of 125 GPM (7.9 lps). An external bypass will need to be installed, or if one already exists, open the external bypass valve gradually until the temperature range in Table 7 is achieved.
8. If it was necessary to adjust the external bypass as outlined in step 7, scribe a line on the bypass shaft and case to mark the correct adjustment position. Wire or remove the valve handle to prevent tampering.

Table 7. Water Temperature Rise and Flow Rates (Measured at Return Header)

Model	Minimum Temp Rise, °F (°C)	Maximum Temp Rise, °F (°C)	Minimum System Flow GPM (lps)
250	8 (4)	12 (7)	30 (1.9)
300	11 (6)	18 (10)	30 (1.9)
400	14 (8)	21 (12)	30 (1.9)

In a system without external bypass, it may be necessary to make changes. If temperature rise is too low, a manual bypass must be installed. If temperature rise is too high, there is inadequate flow, possibly requiring a change to the piping system or a larger pump. Before proceeding with either remedy, verify proper heater operation. Low gas input results in low temperature rise and vice-versa. A problem with the heater internal bypass assembly also affects measured temperature rise.

7.9 Burner Throat Pressure Adjustment

The burner throat pressure should be adjusted using the air orifice on the intake of the fan. This air orifice has a slider attached to it. This slider is used to increase or decrease air pressure. The air pressure will drop as more of the slider covers the air orifice. The air pressure will increase as more of the air orifice is exposed. The pressure should be adjusted to 1.0" WC. See Section 10.4.

Section 8. Maintenance

8.1 Water Chemistry

The mineral content of swimming pool water increases daily due to natural evaporation and the addition of sanitizing chemicals. If the mineral concentration in the pool gets too high, the excess minerals will deposit on the walls of the pool, in the filter system, and in the heater tubes.

The proper chemical balance in spa water is more critical than in a swimming pool heater operation. Due to the spa's size, high water temperature and heavy usage, chemical values in a spa can vary greatly. This chemical imbalance can result in unsanitary water conditions, and affect the life of the heater.

Proper chemical balances are necessary for sanitary bathing conditions as well as ensuring your heater's long life. Kits are available from your local pool supply dealer for making the various tests for mineral content. One of these kits will detect copper in the system. This is usually a warning that corrosion is taking place, possibly due to a low pH value combined with other chemistry problems. The condition can be corrected by changing the spa water and closely monitoring the pH factor and chemical properties of the water. Be sure to keep your chemical levels within the values indicated in Table 8. **Zodiac Pool Systems, Inc. does not warrant heat exchangers damaged by corrosive chemical levels or excess dissolved solids in pool or spa water.**

For spas, it is also necessary to perform water changes in addition to chemical treatment. It is recommended to change the spa water every 60 days for light usage and every 30 days if usage is heavy.

Table 8. Optimal Water Chemistry Ranges*

Test	Recommended Level
Free Chlorine	1.0 to 3.0 ppm
Bromine	2.0 to 4.0 ppm
pH	7.2 to 7.8 (Ideal range is 7.4 to 7.6)
Total Alkalinity (TA)	80 to 120 ppm
Calcium Hardness (CH)	175 to 400 ppm
Cyanuric Acid	50 to 75 ppm
Total Dissolved Solids (TDS)	1000 to 2000 ppm (Excluding dissolved NaCl from a Salt Chlorine Generator)
Copper	0 ppm
* Concentration levels taken from <i>Basic Pool and Spa Technology</i> published by APSP (Association of Pool and Spa Professionals).	

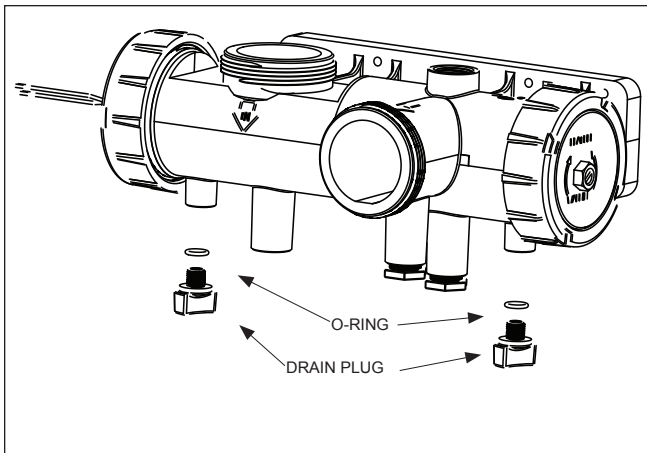

Figure 33. Draining the Heater

8.2 Seasonal Care

⚠ CAUTION

Do not operate this heater outdoors at temperatures below 20 degrees Fahrenheit (°F) (-7 degrees Celsius [°C]).

⚠ ATTENTION

Ne faites pas fonctionner cet appareil à l'extérieur à des températures inférieures à 20 degrés Fahrenheit (°F) (-7 degrés Celsius [°C]).

8.2.1 Spring and Fall Operation

During periods when the pool is only going to be used occasionally, set the pool and spa control temperatures to 70°F (21°C) on the LXi or the lowest setting possible on the LXi. See *Section 7.3.3*. This prevents the pool water from becoming chilled, and minimizes the time required to raise the pool water back up to the desired temperature.

If the heater is not going to be used for a long period of time, shut it down completely. Follow the instructions found on the inside of the heater, or Figure 29.

8.2.2 Winterizing

In areas where freezing temperatures occur in winter and the pool or spa will not be used, have your service technician perform the following steps:

1. Turn off the main gas supply to the heater, using the gas cock outside the heater jacket.
2. Remove heater door.
3. Shut down the heater following the shutdown instructions found on the inside of the heater or refer to Figure 29.
4. Remove the drain plugs from both the inlet/outlet header and the return header (see Figure 33 and Sections 11.3 and 11.4, Exploded Views), and completely drain the heater before the first frost.

5. After all water has drained from the heater, check for mineral buildup in the openings.
6. Use compressed air to blow out any standing water remaining in the heat exchanger.
7. Inspect the gaskets on the drain plugs and reinstall plugs, but do not tighten.
8. Disconnect the pressure switch from the siphon loop (copper tubing).
9. Cover the vent grill so that snow will not accumulate in the combustion chamber, where it may freeze.

8.2.3 Spring Start-up

To restart the heater in the Spring, have a qualified professional technician reassemble the heater as follows:

1. Tighten the drain plug.
2. Uncover the vent grill.
3. Make sure that power is supplied to the pump. Turn on the filter pump and circulate water through the heater for 5 minutes. Check for leaks while circulating.
4. Turn on the main gas supply to the heater at the gas cock outside the heater jacket.
5. Turn on the heater following the lighting instructions found on the inside of the heater, or Figure 29.

8.3 Inspection and Service

The LXi heater is designed and constructed to provide long performance life when installed and operated properly under normal conditions. Periodic inspections, especially at spring start-up, are important to keep your heater running safely and efficiently through the years. Improper maintenance can result in conditions where nausea or asphyxiation from carbon monoxide or flue gases could cause severe injury, property damage or death.

⚠ WARNING

Improper installation or maintenance can cause nausea or asphyxiation from carbon monoxide in flue gases which could result in severe injury, or death.

⚠ AVERTISSEMENT

Une installation ou un entretien inadéquat peut causer la nausée ou l'asphyxie en raison du monoxyde de carbone présent dans les gaz de combustion et même entraîner des blessures graves ou la mort.

8.3.1 Owner Inspection

Zodiac Pool Systems, Inc. recommends that you inspect the heater on a continual basis and especially after abnormal weather conditions. The following basic guidelines are suggested for your inspection:

1. Keep the top and surrounding area of the heater clear of all debris.
2. Keep the area around and beneath the heater clean and free of all combustible materials such as paper, leaves, etc.

<p>⚠ CAUTION</p> <p>Do not store or use gasoline or other flammable vapors, liquids or chemicals in the vicinity of this or any other appliance.</p>
<p>⚠ ATTENTION</p> <p>Ne pas entreposer ni utiliser d'essence ni d'autres vapeurs ou liquides inflammables à proximité de cet appareil ou de tout autre appareil.</p>
<p>⚠ WARNING</p> <p>Do not use this heater if any part has been under water. Immediately call a qualified service technician to inspect the heater and replace any part of the control system and any gas control which has been under water.</p>
<p>⚠ AVERTISSEMENT</p> <p>N'utilisez pas cet appareil s'il a été plongé dans l'eau, même partiellement. Faites inspecter l'appareil par un technicien qualifié et remplacez toute partie du système de contrôle et toute commande qui ont été plongés dans l'eau.</p>

3. If the heater is equipped with a pressure relief valve, check for corrosion in and around the valve. Twice a year, with the filter pump on, lift the release lever on the top of the valve to make sure that water runs freely through it. If corrosion is found, replace the pressure relief valve. When replacing the valve, be sure that the pump is off. Install the valve so that the discharge is directed away from any area that may be damaged by water.
4. Be sure all combustion air and ventilation openings are not blocked. Check for spider webs and other debris inside the heater, in the vents on all sides of the heater jacket and in the exhaust outlet – especially after a long period of non-use.

8.3.2 Professional Inspection

Inspections performed at least once a year by a qualified technician are required to maintain your heater's safe and efficient operation. The following basic safety checks must be performed.

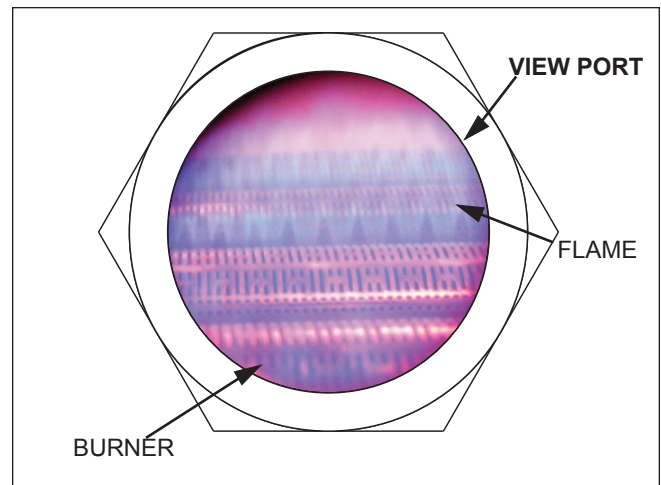

Figure 34. Flame View

1. Check for loose or broken wires and terminal connections.
2. Make sure that the pressure switch operates properly by shutting the filter pump off and on a few times. The burner should go off immediately after the pump stops. The fan will continue to run for 45 seconds after the burner shuts down. An ignition sequence should start shortly after the pump is turned back on.
3. Inspect the electrical controls, specifically:
 - a. High limit controls.
 - b. Water pressure switch.
 - c. Automatic gas valve.
 - d. Fusible link.
 - e. Power interface/Temperature control.
 - f. Control circuit fuse.
 - g. Ignition control.
 - h. Air pressure switch.
4. Inspect the venting system for blockage, leakage, and corrosion.
5. Inspect the combustion blower for damage.
6. Check for spider webs or other obstructions in the main burner orifices – especially at Spring start-up. Clean with wire brush if necessary.
7. Conduct a normal operating cycle and observe that the sequence proceeds as intended.

<p>⚠ CAUTION</p> <p>For your safety, when starting the heater, keep your head and face away from the burner area opening to prevent any risk of personal injury.</p>
<p>⚠ ATTENTION</p> <p>Pour votre sécurité personnelle, lorsque vous mettez l'appareil en marche, tenez votre tête et votre visage loin du brûleur pour éviter tout risque de blessure.</p>

8. If the heater is equipped with a pressure relief valve, clean any accumulated corrosion and make sure that water runs freely.
9. Inspect the outside of the combustion chamber and burner for corrosion and indication of improper operation.
10. Perform a temperature rise test in accordance with *Section 7.8*.
11. Regularly inspect electrical controls for deterioration. Repair and replace as necessary.
12. Make a visual check of the main burner flame. The flame can be seen in a view port on the lower right side of the heater. The flame should be light blue in color and short (see Figure 34). If flame appearance is otherwise, adjustment is necessary as described in the following section.

NOTE After installation and first start-up, check the heat exchanger for black carbon soot buildup after the following periods of operation: 24 hours, seven (7) days, 30 days, 90 days and once every six (6) months thereafter.

NOTE Keep this manual in a safe place for future reference by you and your professional technician when inspecting and servicing the heater.

Section 9. Troubleshooting

9.1 General Heater Troubleshooting

Table 10 lists some of the more common problems, causes and solutions encountered when running the heater. Most problems occur when the heater is being started for the first time after installation or at Spring start-up. Careful installation and maintenance will help ensure years of trouble free use from your LXi heater.

Be aware that premix combustion systems of the type found in the LXi heaters have special characteristics that affect operation and troubleshooting. See *Section 10.2* and *Section 10.3* for important information about the system.

9.2 Service Codes

The LXi controller monitors several functions of the heater. In the event of a malfunction, the LXi controller will display a FAULT message. Table 11

lists the LXi Heater Service Codes along with potential causes and remedies.

9.3 Ignition Control LED Service Codes

In addition to the service codes shown in the previous section, the ignition controller in the LXi heater has an LED light that flashes to indicate various different faults. Table 9 lists the LED codes and the corresponding fault description:

Table 9. Ignition Control LED Fault Codes

LED Code	Fault Description
The LED light is on continuously.	Ignition Control Fault. Refer to qualified service personnel.
LED single flash.	Air flow fault.
LED double flash.	Flame exists when there is NO call for heat. Refer to qualified service personnel.
LED triple flash.	Ignition lockout (heater has cycled three (3) times and has locked out after the third try).

Table 10. LXi Troubleshooting Guide

#	Symptom	Cause	Remedy
1.	Pump not operating	A. No power B. Pump defective C. Incorrectly wired D. Time clock settings not synchronized with actual time	A. Check circuit breakers and power source. B. Replace. C. Recheck wiring. D. Check time clock setting.
2.	Flashback on start-up	A. Wrong gas B. Burner damage	A. Make sure gas supply matches gas indicated on rating plate. B. Replace burner.
3.	Lazy flame with yellow tip	A. Wrong gas	A. Make sure gas supply matches gas indicated on rating plate.
4.	Flame lifts and goes out	A. Lean fuel/air mixture—Low supply pressure B. Lean fuel/air mixture—Too much combustion air	A. Correct supply pressure to assure 2.5" W.C. (Natural) or 9.0" W.C. (Propane) manifold pressure when firing. B. Check burner throat pressure, adjust to 1.0" W.C.
5.	Short yellow streaked flame	A. Rich fuel/air mixture— Hi manifold pressure B. Rich fuel/air mixture— Too little combustion air	A. Correct manifold pressure to 2.5" W.C. (Natural) or 9.0" W.C. (Propane). B. Locate and correct combustion system sealing beneath burners (see Section 10.3). Check burner throat pressure, adjust to 1.0" W.C.
6.	Not enough heat	A. Inadequate gas supply B. Low manifold gas pressure C. Heater size inadequate D. Temperature rise set incorrectly	A. Gas meter too small. Gas line from meter to heater too small. B. Gas pressure on heater manifold, should be adjusted to 2.5" W.C. (Natural), 9.0" W.C. (Propane). C. Replace with heater of higher input. D. Adjust temperature rise according to Section 7.8 of this manual.
7.	Heater pounding or knocking	A. Water flow through heater or knocking	A. Check temperature rise according to Section 7.8 of this manual. If temperature rise is too high, check pipe size, pump capacity. Look for obstruction or closed valve in system. Check for damaged internal bypass or external bypass set wrong.
8.	Heater condensing	A. Low water temperature B. Heater plumbed backwards	A. Flue product moisture will condense at the start-up until the heater water temperature reaches the normal operating conditions. B. Correct Plumbing.
9.	Igniter lights but main burners will not come on	A. Gas valve not at "on" position B. Air in gas line C. Gas valve failed D. No power to gas valve E. Low gas pressure F. High burner throat pressure	A. Turn knob to "on" position. B. Cycle ignition sequence until air is out of the gas line. C. Replace gas valve. D. Check controls for proper operation. E. Check supply pressure and manifold. F. Check burner throat pressure.

Table 11. LXi Heater Service Diagnostic Guide

DISPLAY FAULT	CAUSE	REMEDY
<i>Display shows</i> FAULT- PUMP	1. Pump is not running.	1. This is a normal display when the control is in a Maintain Temp mode. No Service Required.
<i>Display shows</i> NO FLOW	1. Pump is not running. 2. Low pump pressure. 3. Pressure switch fault.	1. Check breakers and power source, recheck wiring, set time clock and current time. 2. Clean filter or clear blockage, check position of valve in plumbing system. 3. Adjust or replace pressure switch. Refer to qualified service personnel.
FAULT- HIGH LIMIT	1. Water temperature in heater exceeds the internal limit. 2. Limit switch fault.	1. Verify function of high limit switches. Perform temperature rise test. Identify and correct cause of overheating. Refer to qualified service personnel. 2. Identify and correct loose connections or replace switches. Refer to qualified service personnel.
FAULT- FUSELINK/FIELD	1. Fusible link fault.	1. Identify and correct loose connections or replace fusible link. Refer to qualified service personnel.
FAULT- CHECK IGN CONTROL	1. Broken, split, pinched or disconnected fan/switch tubing. 2. Fan not operating. 3. Fan running slow or premature fan failure. 4. Air flow restricted at intake or discharge. 5. Oscillating pump pressure. 6. Low gas supply pressure. 7. No flame at burners.	1. Check tubing and replace if necessary. 2. Correct fault or replace fan. Refer to qualified service personnel. 3. Verify proper wiring for 120 VAC or 240 VAC. Refer to qualified service personnel. 4. Check for proper clearances around heater and for adequate room ventilation if enclosed. Inspect for blockage or restriction at discharge of flue. Refer to qualified service personnel. 5. Clean filter or identify and repair cause of pump oscillation. 6. Identify and repair incorrect supply pipe size or pipe line blockage. 7. Identify and correct loose wiring connections, or problems with igniter, flame sensor, gas valve, or ignition control. Refer to qualified service personnel.
FAULT- SHORTED H2O SENSOR or FAULT- OPEN WATER SENSOR	1. Faulty wiring or connection. 2. Failed sensor.	1. Inspect sensor wiring. Ensure sensor is connected into Power Interface Board. 2. Replace temperature sensor. Refer to qualified service personnel.

Section 10. Professional Maintenance and Service

⚠ WARNING

SERVICING SAFETY

Some of the servicing procedures for the LXi heater are hazardous because they involve fuel gas, electricity, moving parts and procedures which require testing or temporary bypass of safety controls. For this reason, the heater must be serviced only by a qualified professional service technician.

IMPROPER SERVICE HAZARD

The LXi heater incorporates unique design features. Incorrect service of this heater can result in personal injury or damage to property. To avoid such hazards, the heater must be serviced only by a qualified professional service technician.

⚠ AVERTISSEMENT

PRÉCAUTIONS LORS DES RÉPARATIONS ET DE L'ENTRETIEN

Certaines procédures d'entretien et de réparation des appareils de chauffage à faibles émissions LXi et LXi présentent des dangers, car elles mettent en jeu des gaz combustibles, des composants électriques, des pièces mobiles et des procédures qui nécessitent des mises à l'essai ou la dérivation temporaire des commandes de sécurité. Pour cette raison, l'appareil de chauffage doit être entretenu et réparé uniquement par un technicien professionnel qualifié.

DANGERS D'UN ENTRETIEN INADÉQUAT

Les appareils de chauffage à faibles émissions comportent des caractéristiques techniques uniques. Une réparation ou un entretien inadéquat peut entraîner des blessures corporelles ou des dommages à la propriété. Pour cette raison, l'appareil de chauffage doit être entretenu et réparé uniquement par un technicien professionnel qualifié.

10.1 General Information

A qualified professional technician must service the LXi pool heater using Zodiac's service procedures. Before calling for service, however, the owner should check for obvious problems. The other components in the pool system, including pump, filters and strainers, water valves, gas supply, electrical power and time clocks, have an affect on heater operation.

Confirm that the heater control is set to either **POOL** or **SPA** and that the corresponding temperature set point is set high enough to make the heater operate. Make sure the pump is operating, that the filter and all baskets are clean, that there are no mis-positioned water valves, that the gas or electric power supplies are not shut off and that time clocks are properly adjusted.

Also be sure that there is no blockage of the exhaust vent grill or rear louvers, which supply combustion air to the burners.

10.2 "Premix" Forced-Draft Combustion System

The LXi pool and spa heater has a forced-draft combustion system incorporating special burners and a combustion blower. The burners are of special design in which the combustion air passes through the burners, resulting in a "premix" process. When burning natural gas, this process produces very little Nitrous Oxide emissions. Air and gas are pushed into the burner venturis where they are mixed and conveyed to the combustion chamber. Hot combustion products pass through a highly efficient heat exchanger, where water absorbs most of the heat. Exhaust is directed to the outdoor air through a grill, or for indoor heaters, through vent piping.

10.3 Heater Components and Their Operation

1. **Gas Valve / Regulator** - The gas valve controls gas flow into the manifold. It provides flow only when the temperature control requires heat and only if all safety controls enable operation. It is also a positive pressure regulator. It regulates the gas pressure in the manifold to specifications addressed earlier in this manual. This is necessary for proper operation of the burner system.
2. **Combustion Blower and Air Orifice** – The blower delivers air to the burners. This air is used to combust the fuel. This air is also used to purge the combustion chamber of unburnt fuel before ignition and after the burners turn off. It is normal for the fan to start before the main flame starts and to continue operating after the flame has ceased. The air orifice controls the amount of air that is delivered to the burners. This orifice is adjustable. The adjustment helps maintain proper combustion. It should be adjusted to specifications addressed earlier in this manual.
3. **Temperature Control** - The LXi heater models are equipped with an electronic control which senses water temperature by means of a thermistor and controls heater operation to bring the water to the temperature selected. It has an option for two (2) separate thermostat settings which are typically used to set pool and spa temperatures.
4. **Ignition Control** - The ignition control provides energy for ignition of the air/gas mixture, monitors the flame and controls the gas valve. When the temperature control calls for heat, the ignition

control provides a pre-purge of the combustion chamber. Once the pre-purge is complete the ignition control then applies electrical power to a "hot surface" igniter. When the igniter is hot enough, the ignition control opens the gas valve. It has sophisticated means to sense ignition and flame condition so that unburned gas will not escape. Once the ignition control has sensed flame, it de-energizes the igniter. After the burner is shut off, the ignition control continues blower operation to provide a post-purge period.

5. **Igniter** - The hot surface igniter is a crystalline element which becomes very hot when electrical power is applied to it. The hot surface igniter directly ignites the air/gas mixture in the combustion chamber.
6. **Limit Switches** - Two (2) limit switches prevent excessive water temperature - one at the heat exchanger outlet and one (1) for water leaving the heater. If either senses excessive temperature, burner operation is interrupted.
7. **Water Pressure Switch** - This control senses whether or not water is available to the heater by measuring back pressure inside of the heat exchanger. If the pool water pump fails or the water filter is blocked, the pressure switch prevents operation of the burner.
8. **Fusible Link** - This is a single-use switch which detects abnormal temperature in the component compartment of the heater. It is a fusible link which is held to the combustion chamber just above the burner tray by a sheet metal bracket. Excessive temperature in the component compartment, possibly due to a burner flash-back will cause the link to fail. This opens the safety circuit which shuts off the gas valve and shuts the heater down.
9. **Air Pressure Switch** - This switch verifies that air is flowing through the combustion system by sensing pressure. It shuts off the heater if air flow is inadequate.
10. **Flame Sensor** - The flame sensor is the electrode through which the ignition control detects "rectification" of current passed through the flame. Inadequate rectification indicates an unsatisfactory flame condition. The rectification signal can be measured by attaching the leads of a DC ammeter to the two pins on the connector of the ignition control labeled "FC". A wire harness, available from Zodiac Pool Systems, Inc., makes it easier to attach the voltmeter leads. The flame current should not be less than 1.5 micro-amps. If the flame signal is less than 1.5 micro-amps, verify correct gas supply and manifold pressures.

10.4 Special Service Issues - Premix Combustion System

10.4.1 System Operation

Premix combustion systems are less tolerant of fuel and air imbalance than other technologies. Fuel gas properties, incorrect supply or manifold pressure affect their operation and reliability. If fuel gas heat content is low, combustion is "lean" and tends to be unstable. Flames may lift off the burner, causing outage. If heat content is high, "rich" combustion results, with low, hot flames that can overheat the burners. Likewise, low gas supply or manifold pressure results in lean, unstable combustion and high manifold pressure results in a rich process and hot burners.

The air pressure inside the burner throat also affects combustion. Incorrect air pressure will affect performance and reliability of the heater. The burner throat pressure should be adjusted to 1.0" W.C. (See *Section 10.4.3* for adjustment procedures.) If the air pressure is too high, combustion will tend to be "lean" and unstable. Flames may lift off the burners and be extinguished. If air pressure is too low, the combustion will be "rich". The flames will be low and hot. This could lead to burner overheating and failure. The burner throat and gas manifold pressure need to be balanced for stable combustion to occur.

The sealing of the combustion chamber and flue assembly is also important to maintaining good combustion. The combustion chamber of the LXi runs at a slightly positive pressure (0.08" W.C. to 0.18" W.C.). It is important that combustion products do not leak from the combustion chamber or flue collector inside the cabinet of the heater where they will be pulled into the combustion air fan. Most of the oxygen in combustion products has been consumed. If these combustion products are pulled into the combustion air fan, it may cause a rich combustion condition and that will lead to a short yellow streaked flame that can decrease burner life. Combustion chamber and flue collector sealing must be maintained in "factory" condition. Service operation involving burner, heat exchanger or fuel collector removal must be conducted with this in mind.

10.4.2 Field Service and Adjustment

As with all gas-fired appliances, the first order of business is to verify correct gas type, supply pressure, manifold pressure, and burner throat pressure as specified on the heater rating plate and in other sections of this manual.

If the problems with lifting or short yellow/orange flames cannot be corrected with the slight change in manifold pressure and burner throat pressure, it is likely that the fuel supply differs greatly from average. In this event, it may be necessary to replace the gas orifices. Contact the Zodiac Pool Systems, Inc., Technical Service Group at 800.822.7933 for assistance.

10.4.3 Burner Throat Pressure Adjustment

The burner throat pressure should be adjusted using the air orifice on the intake of the fan. This air orifice has a slider attached to it. (See Figure 35.) This slider is used to increase or decrease air pressure. The air pressure will drop as more of the slider covers the air orifice. The air pressure will increase as more of the air orifice is exposed. The pressure should be adjusted to 1.0" W.C. To measure the air pressure locate the burner throat pressure tap. (See Figure 36). Remove the plug covering the tap and measure the pressure.

10.5 Electrical Troubleshooting

This section describes procedures for checking the electrical power and control components of the heater one (1) at a time and in the order they appear in the control circuit. It is important to follow the sequence of this troubleshooting guide because the safety circuit is connected in series.

These procedures require a Volt-Ohm meter with a minimum 0-250VAC voltage range, and 1-1000 Ohm resistance range. Figure 37 shows the power and control circuits and where to take measurements. Location numbers in circles have been added, and will be referenced in the following sections.

Where test points are shown at circuit board connectors, the probe of the meter can be carefully pushed into the connector along side of the wire at the connection to be measured.

The electrical power supply can be checked with the heater not set to fire. All other procedures need to be checked with power correctly supplied to the heater, all external devices set so that the heater is allowed to fire and the heater's thermostat set so that there is a call for heat.

As stated at the beginning of the manual, some of these procedures are hazardous. Only a qualified service technician should service the heater.

10.5.1 Electrical Power Supply

The electrical components of the LXi pool heaters are designed to operate with supply voltage ranging from 102V to 132V at 60 Hz if connected to a nominal 120 Volt power supply, or 204V to 264V at 60 Hz if connected to a nominal 240 Volt power supply. Measure supply voltage at the power supply leads where they enter the heater (identified as points A, B and C on the wiring diagram in Figure 37). Use the voltages in Table 12 to verify that the correct voltage is supplied to the heater.

If no voltage is present, correct this external power supply problem to the heater. Circuit breakers, time clock settings or similar devices may be the problem. Voltage outside of the above ranges may be due to poor wiring, poor connections, other loads such as air conditioning compressors or to an electric utility company problem. Arrange for correction of the voltage as appropriate.

When you are sure that the voltage supplied to the heater is correct, check the voltage being supplied to the transformer by the power supply circuit board.

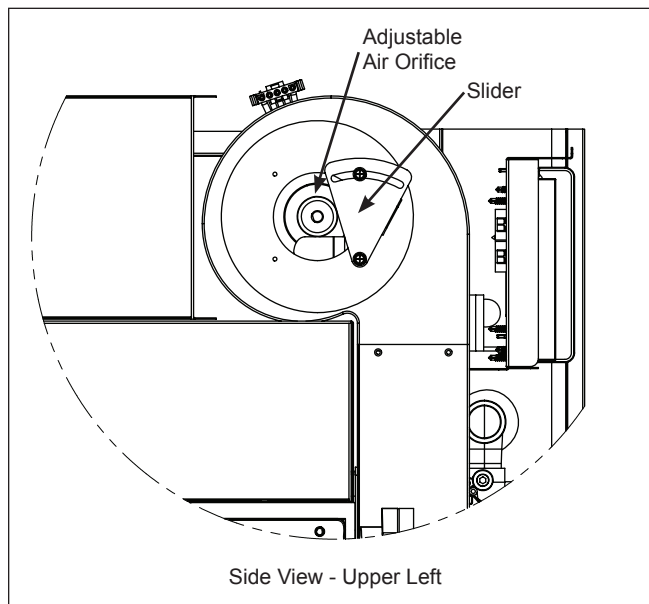

Figure 35. Adjustable Air Orifice Location

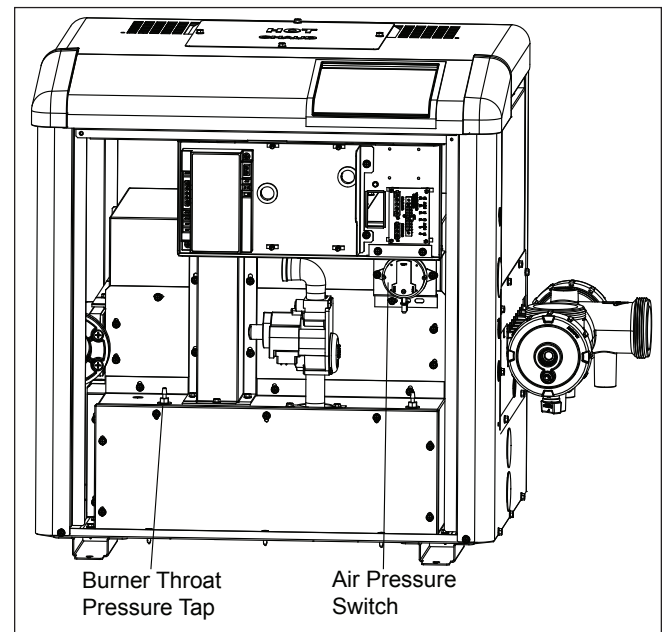

Figure 36. Air Pressure Switch and Burner Throat Pressure Tap Location

This can be done by measuring the voltage between the wires of the three-pin connector on the power supply circuit board. These points are designated as test points D, E, and F on Figure 37. The voltages measured between any two (2) of these three (3) points will be determined by the voltage supplied to the transformer. See Table 13 for expected voltages.

If the voltages measured do not fall within the limits shown in Table 13, then there is a problem with the power supply circuit board and the board must be replaced.

Table 12. Supply Voltage Measurements

MEASURE BETWEEN THESE POINTS	EXPECTED VOLTAGE WITH 240V SUPPLY	EXPECTED VOLTAGE WITH 120V SUPPLY
A and B	102 - 132 Volts	0
A and C	102 - 132 Volts	102 - 132 Volts
B and C	204 - 264 Volts	102 - 132 Volts

- Point A is the ground connection on the heater.
- Point B is the location at which the red power lead enters the power circuit board.
- Point C is the location at which the black power lead enters the power circuit board.

Table 13. Voltage Supplied To Transformer

MEASURE BETWEEN THESE POINTS	EXPECTED VOLTAGE WITH 240V SUPPLY	EXPECTED VOLTAGE WITH 120V SUPPLY
D and E	102 - 132 Volts	102 - 132 Volts
D and F	204 - 164 Volts	N/A
E and F	102 - 132 Volts	0

- Point D is the location at which the white wire enters the 3 pin connector.
- Point E is the location at which the black wire enters the 3 pin connector.
- Point F is the location at which the blue wire enters the 3 pin connector.

10.5.2 Controller

The controller must be operational in order to check the control circuits of the heater.

10.5.3 Control Circuit Troubleshooting

The heater controls are arranged in several 24V 60Hz circuits with some operating and safety controls arranged in series circuits.

Troubleshooting is done by probing for voltage between the common and various points in the circuit to determine which component is preventing operation. Check points are indicated on Figure 37. The black lead of the meter should be attached to the common tap on the secondary side of the transformer and may be left there throughout most of the procedure.

The recommended procedure steps through each circuit in a sequential way, and each section assumes

that components from all previous sections have been tested and are operational. However, verifying voltage at any of the numbered points in that circuit confirms that all prior components of the circuit are operational.

10.5.3.1 Transformer

Set the voltmeter to measure AC voltage. Attach the black lead of the voltmeter to the terminal on the secondary side of the transformer with a yellow wire attached to it (common). This is test point 1 on Figure 35. Touch the free lead of the voltmeter to the terminal on the secondary side of the transformer with a red wire attached to it (24V tap), test point 2. The voltmeter should read between 20-28 Volts AC.

10.5.3.2 Fuse

Leave the black voltmeter lead in place at test point 1. Touch the free lead of the voltmeter to test point 3, which is on the Power Interface Board where the red wire from the transformer enters the end of the connector. You will need to push the voltmeter lead into the back of the connector along side of the wire pin. The meter should read 20-28 Volts AC.

If there is no voltage, the fuse has failed. Inspect the rest of the wiring, especially the safety circuit, to be sure that there is no “short” such as contact of a terminal with the heater chassis or another terminal which may have caused the fuse to fail.

Correct any such condition and replace the fuse. Use only a 2 amp, 1¼ inch long x ¼ inch diameter, fast-acting, glass-tube type fuse.

10.5.3.3 Water Pressure Switch

Start by checking the voltage at the two (2) legs of this circuit on the controller. (See test points 4 and 5 in Figure 35. Check the voltage at test point 4, where the violet wire from the pressure switch enters the two-pin connector on the controller.

If there is not 20-28 Volts AC nominal at this point, either the controller or the two-pin wire harness is faulty and must be replaced.

If 20-28 Volts AC nominal is detected at test point 4, then move the red lead of the meter to test point 5 where the gray wire from the Pressure Switch enters the two-pin connector. If 20-28 Volts AC nominal is detected at this point, the devices in this circuit are closed and the circuit is working properly.

If there is no voltage the pressure switch contacts are open. This is almost always due to a water flow deficiency, the most common one being a blocked water filter or defective pump. However, sometimes it is due to blockage of the copper siphon loop tube or mis-adjustment of the switch.

Investigate thoroughly, referring to *Section 7.7, Adjustment of Pressure Switch*. If there is no problem with the pool system or pressure switch adjustment, replace the pressure switch.

10.5.3.4 Fusible Link

To check the fusible link/air louver/field interlock circuit, place the red lead at test point 6. If there is not 20-28 Volts AC nominal, either the controller or the two-pin wire harness is faulty, or the water pressure switch is open.

If 20-28 Volts AC nominal is detected at test point 6, then move the red lead of the meter to test point 7. If 28 Volts AC nominal is detected, the circuit is closed and working correctly.

If the proper voltage is not detected, either the fusible link or field interlock has opened, or the wire harness is faulty. Failure of the fusible link must be investigated further to identify the cause of the failure.

10.5.3.5 Temperature Limit Switches Circuit

Since the limit switches are not easily accessible, the voltage can be checked at the two (2) legs of the circuit at the controller. See test points 8 and 9 in Figure 37.

Check the voltage at test point 8. If there is not 20-28 Volts AC nominal at this point, either the controller or the two-pin wire harness is faulty, or one of the two (2) safeties (water pressure or fuselink) before it is open.

If 20-28 Volts AC nominal is detected at this point, then move the red lead of the meter to test point 9, where the black wire from the 130° limit enters the two-pin connector. If 20-28 Volts AC nominal is detected at this point, the devices in this circuit are closed and the circuit is working properly.

If there is no voltage, one (1) of the limit switches is open. This is normally due to excessive water temperature, which should be thoroughly investigated before replacement of limit switches. Excessive water temperature may be caused by low water flow. Water flow deficiency may be due to obvious problems such as a defective pump or blocked water filter.

Alternatively, excessive water temperature may be due to over-firing, or to a problem with the water piping or the heater's internal bypass control. Over-firing might be a result of an incorrect gas orifice or supply of propane gas to a heater intended for natural gas.

If there are no such fundamental problems, identify which of the switches is open. Limit switch access is through the limit switch plugs on the side of the heater to which water pipes are connected. Remove the limit switch plugs from the bottom of the header and gently remove the switches from the wells.

Note that the limit switches have different trip points, and it is important that replacements are correct. The 150°F switch has a red dot on the top of the switch, and must be installed in the lower well in the header. The 130°F switch has no dot and must be installed in the upper well in the outlet of the header.

Move the red meter lead to the terminal connection on the 150° switch that is connected back to the controller. The voltmeter should read 20-28 Volts AC nominal. No voltage here means that the two-pin wire harness is bad and should be replaced.

If voltage is detected at this point, move the lead to the other terminal of the switch. If the voltmeter does not show voltage, then the 150° limit is bad and should be replaced.

If the meter reads 20-28 Volts AC nominal, move the lead to the terminal of the 130° limit that is connected to the wire that jumps between the two (2) limit switches. No voltage here means that the wire assembly is bad and needs to be replaced. 20-28 Volts AC nominal shows that the wire between the two (2) limits is making a good connection.

Now move the lead to the other connection terminal on the 130° limit. No voltage at this point indicates that the limit switch has failed and needs to be replaced. Voltage here would show that the limit is good and that the two-pin wire harness may have a bad connection. Replace the wire harness if necessary.

10.5.3.6 Blower Pressure Switch Circuit

The blower must be operating during the test procedure for the blower pressure switch. Start by checking the voltage between test point 1 and the common and normally open contacts of the air flow switch.

Leaving the black lead of the meter on test point 1, check the voltage at test point 11. If there is not 20-28 Volts AC at this point, the eight-pin wire harness is faulty and must be replaced. If 20-28 Volts AC is detected at this point, then move the red lead of the meter to the Air Flow Switch NO contact. If 20-28 Volts AC is detected at this point, the device in this circuit is closed and the circuit is working properly.

If there is not 20-28 Volts AC at the Air Flow Switch NO contact, the pressure switch contacts are open. This is usually due to a blower speed problem or a problem with the air pressure tube connection between the blower housing and the switch.

Be sure that the blower is on and that it is working properly. Check that the gray flexible tube between the blower pressure switch and the blower housing is connected at both ends and has no holes or splits. Replace the tube if necessary. If there is no problem with the blower or the tube, check for blockages in the vent, flue or heat exchanger that would prevent air flow. If no blockages are found, replace the pressure switch.

If the Air Flow Switch NO contact shows 20-28 Volts AC and the ignition control shows an air flow fault, then there is a bad connection between the blower pressure switch and the ignition control, or the ignition control is faulty.

Check for voltage at test point 12 on the ignition control. If no voltage is present, then the connection is bad, replace the wire harness. If 20-28 Volts AC is present, replace the ignition control.

10.5.3.7 Gas Valve Voltage

The gas valve will operate only when there is a call for heat, all safety circuits have been satisfied, and the hot surface igniter has had power for approximately 35 seconds. If the gas valve does not operate under these conditions, check the voltage going to the gas valve. Place one voltmeter lead in the two-pin connector on the controller where the yellow wire is connected (test point 14). Touch the free lead of the meter to the gas valve terminal where the brown wire is attached at the gas valve. This test point will have voltage present only during a trial for ignition or during normal operation. The meter should read 20-28 Volts AC. If there is no voltage, then there is a bad connection between the gas valve and the ignition control. Replace the wire harness.

Listen closely to the gas valve when it is first energized (24V first appears at test point 13 during the trial for ignition). There should be an audible “click” when the valve opens.

If there is voltage at the gas valve terminal where the brown wire is attached, but the gas valve does not open, replace the valve.

10.5.3.8 Igniter/Ignition Control Circuit

WARNING

The igniter, power supply circuit board and some terminals of the ignition control utilize 120V or 240V power and require appropriate servicing precautions. Note that wires and terminals of these components may be “hot” even when the component is not operating.

AVERTISSEMENT

Le dispositif d'allumage, le circuit d'alimentation électrique et certaines bornes de la commande d'allumage utilisent une tension de 120 V ou de 240 V et exigent des précautions appropriées lors du service d'entretien et de réparation. Notez que les fils et les bornes de ces composants peuvent être chauds même si le composant ne fonctionne pas.

With the igniter energized, there will be voltage of 102-132 VAC between the IGN120 and IGNFS terminals on the ignition control, test point J and test point K, if the heater is connected to a 120V supply.

If the heater is connected to a 240V supply, then the voltage reading between these two (2) points will be 102-132 VAC if the transformer is working properly. This voltage will be applied only during igniter heat up or trial for ignition. Even if voltage has been confirmed at the end of the safety circuit, the “trial for ignition” sequence is imposed by the ignition control.

This sequence consists of a 15-second period of pre-purge, a 40-second period for heat-up of the igniter, and a 7-second trial for ignition. During this last

47 seconds there is voltage between test point J and test point K. If satisfactory ignition is not achieved, the igniter is turned off and the system waits for a 15 second inter-purge period. The system may go through this cycle as many as three (3) times, but thereafter it is “locked out” by the ignition control for a 1 hour period. Additional attempts will be made only if the call for heat is interrupted by turning off electrical power or setting the control to “Off” and then back to “Pool” or “Spa” or after the one hour delay.

To trouble shoot the ignition control's igniter circuit, connect the voltmeter leads at test points J and K, and set the control to call for heat. Observe that the normal ignition sequence takes place. After the 15 second pre-purge, note the voltage between test points J and K. Then look for the glow of the igniter through the view port on the right side of the combustion chamber. If the correct voltage is detected between points J and K during the trial for ignition but the igniter does not glow, check the connections to the igniter.

Check the igniter with the ohmmeter. Disconnect the IGN120 and IGNFS terminals from the ignition control. Place one lead of the meter on each wire to the igniter. The resistance should read between 40 and 75 Ohms at ambient air temperature.

If the meter reading is outside of this range or shows an open or short circuit, replace the igniter. If a short circuit is indicated, it is necessary to investigate further to find if the short is from the igniter or the flame sense circuit. Remove the air plenum cover and test the igniter resistance at test points H and I. If a short is indicated, replace the igniter. If not, look for the short in the flame sense circuit. Correct the short and replace any damaged wiring and the flame rod if necessary.

If voltage does not appear between points J and K during the trial for ignition, there may be a bad connection, faulty transformer, or a short on the ignition control. Check all connections, the transformer, and the ignition control for loose or corroded connections or failure and replace as necessary.

This page is intentionally left blank.

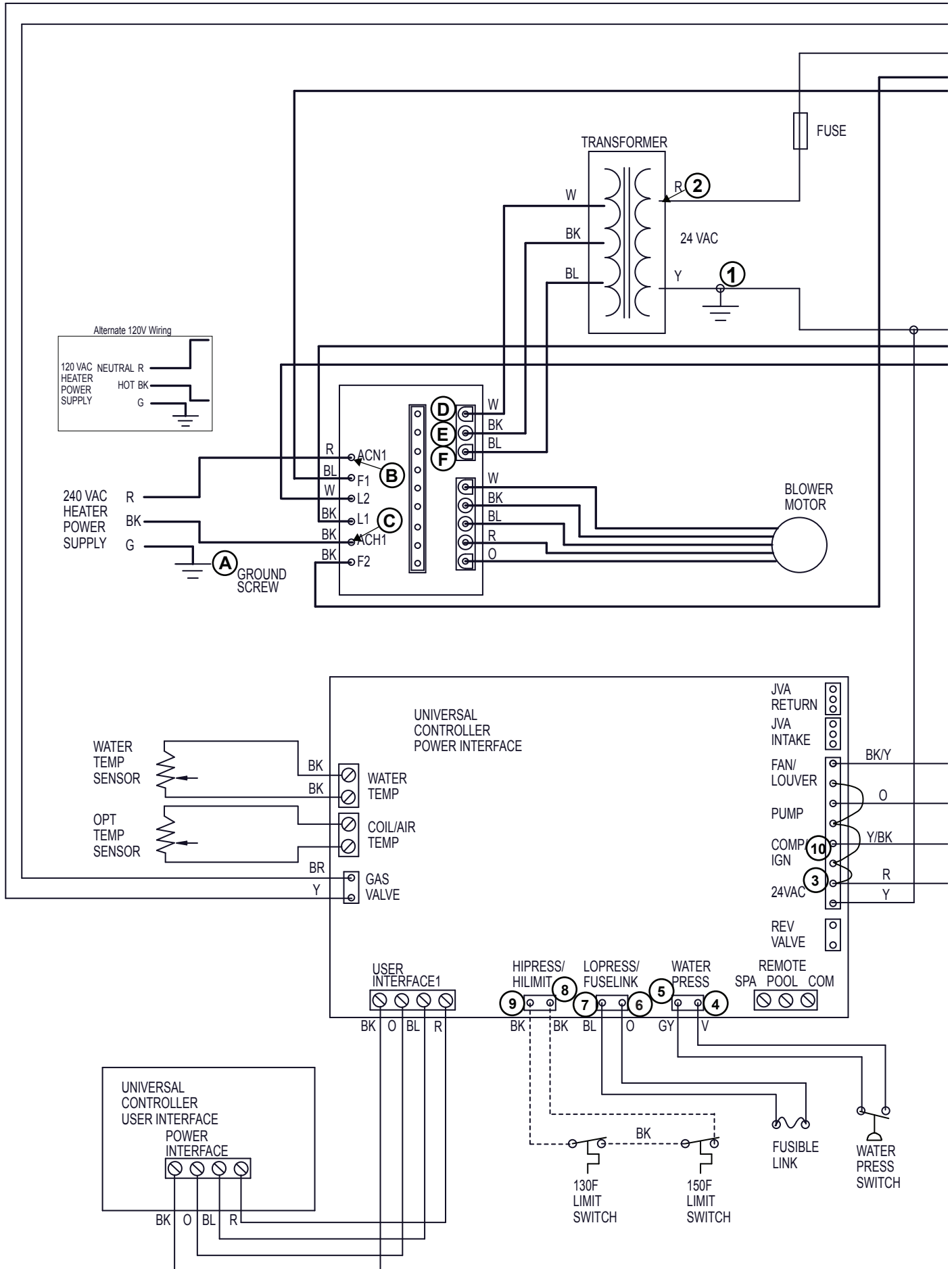
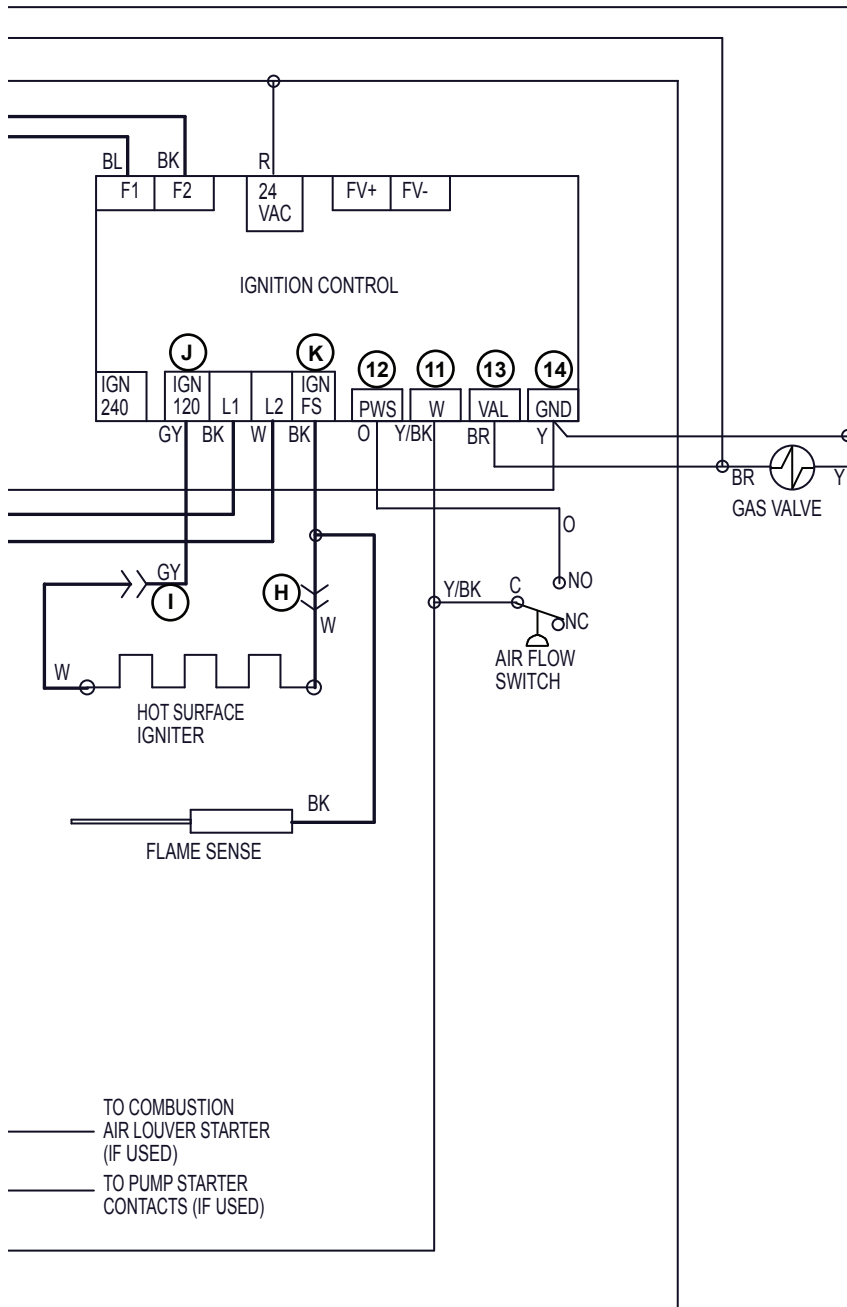

Figure 37. Test Point Identification Diagram (1 of 2)



TO COMBUSTION
AIR LOUVER STARTER
(IF USED)

TO PUMP STARTER
CONTACTS (IF USED)

- Factory Wired 24V
- Factory Wired 120V/240V
- BK - BLACK
- BK/Y - BLACK WITH YELLOW TRACE
- BL - BLUE
- BR - BROWN
- G - GREEN
- GY - GRAY
- O - ORANGE
- R - RED
- V - VIOLET
- W - WHITE
- Y - YELLOW
- Y/BK - YELLOW WITH BLACK TRACE

Figure 37. Test Point Identification Diagram (2 of 2)

Section 11. Replacement Parts

11.1 Ordering Information

To order or purchase parts for the LXi pool and spa heater, contact your nearest Jandy dealer or distributor. Access the Jandy web site at www.jandy.com for the nearest service center. If it cannot supply you with what you need, contact Zodiac Pool Systems, Inc. Customer Service Department at 800.822.7933.

NOTE To order the correct part, it is important that you state the model number, serial number and type of gas when applicable. This information is on the rating plate inside the heater.

11.2 Parts List

Key No.	Description	Model No.	Order Part No.
Heat Exchanger Components			
1	Complete Heat Exchanger (Copper)	250,300,400	R0453303,04,05
1	Complete Heat Exchanger (CuNi)	250,300,400	R0501003,04,05
2	Tube Assy (Cu), w/ Hdwr & Gskts	250,400,300	R0453403,05,06
3	Heat Exchanger End Baffles	250,400,300	R0453503,05,06
4	Front Header, w/ Hdwr & Gskts	All	R0453600
5	By-Pass Assy, Complete	All	R0453700
6	Hardware and O-rings, Bypass	All	R0453800
7	Spring, Bypass	All	R0453900
8	Coupling Nut Kit, w/ O-ring, (Set of two)	All	R0454000
9*	O-ring, Coupling, (Set of 2)	All	R0454100
10	Rear Header, w/ Hdwr & Gskts	All	R0454200
11	Gasket, Header, Front or Rear, (Set of 16)	All	R0454300
12	Header Drain Plug w/ O-ring (Set of 3)	All	R0454400
13*	Heat Exch. Hardware Kit & Gaskets	All	R0454500
14	Cap Sensor/Press Switch O-ring	All	R0455400
15	Return Header Cap & O-ring	All	R0454600
Gas Components			
16	Burner w/ Gasket	All	R0454700
16	Burner w/ Tap and Gasket	All	R0454701
17	Manifold, Gas, Nat	250,300,400	R0454803,04,05
17**	Manifold, Gas, LP	250,300,400	R0455003,04,05
18	Gas Valve Nat w/ Street Elbow	All	R0455200
18	Gas Valve LP w/ Street Elbow	All	R0455300
Exhaust System			
19	Flue Collector w/ Gaskets	250,300,400	R0455503,04,05
20	Blower Assy w/ Gasket	All	R0455600
21	Air Orifice Adjust Bracket	All	R0455700
22	Flue Vent Assy w/ Gasket, Split Flue	250,300,400	R0495503,04,05
23	Hot Plate, Split Flue	250/300,400	R0495401,02
24*	Vent Hardware Kit	All	R0456100
25	Flue Box Assy w/ Gasket	All	R0456200
26*	Side Wall Vent Kit	250/300,400	R0467301,02
Electrical			
27	Transformer	All	R0456300
28	Air Pressure Switch	All	R0456400
29	Temperature Sensor (Regular)	All	R0456500
29	Temperature Sensor (Salt)	All	R0477300
30	Gasket, Temperature Sensor	All	R0456600
31	Plastic Sleeve, Temperature Sensor	All	R0456700
32	Plug Sensor	All	R0456800

NOTES:

- All hardware sets contain all pieces necessary for assembly, including gaskets.
- Gaskets and hardware are included in all kits that involve the removal of a gasket as part of the procedure to replace a part.

* PARTS NOT SHOWN ON KEY VIEW

** MANIFOLD KIT INCLUDES INSTALLED ORIFICES BUT DOES NOT INCLUDE GAS VALVE

Key No.	Description	Model No.	Order Part No.	Components of ASME-Certified Heat Exchanger		
	Electrical (Continued)			72	Heat Exch Tube Assy, CuNi	250,300,400 R0477003,05,06
				73	Header, In/Out, Bronze	250,300,400 R0476603,05,06
33	Ignition Control	All	R0456900	74	Header, Return, Bronze	250,300,400 R0476700
34	Water Pressure Switch Assy	All	R0457000	75	Heat Exch Hdwr, Bronze	250,300,400 R0477200
35	Water Pressure Switch, 2 psi	All	R0013200	76	Header, Bypass Assy w/ Hdwr	250,300,400 R0476803,05,06
36	Water Pressure Switch Tubing	All	R0457100	77	Header, Bypass Spring	250,300,400 R0476903,05,06
37	High Limits Set	All	R0457200	78	Bypass, Gasket	250,300,400 R0011400
38	High Limit 130°F	All	R0457300	79	Temp Sensor, Mounting Brkt	250,300,400 R0477400
39	High Limits 150°F	All	R0023000	80	Tube Assy, Pressure Switch	250,300,400 R0477500
40	Harness, High Limit Switch	All	R0457400	81	Flange & Gasket Assy, Set of 2	250,300,400 R0477600
41	Hot Surface Igniter	All	R0457500	82	Header, Flange, Bolts	250,300,400 R0477800
42*	Wire Harness Set Complete	All	R0457600	83	Header, Plug, ¼ NPT	250,300,400 R0477900
43*	Harn Pwr Interface Controller (Fuse Included)	All	R0457700	84	Header, Drain Plug	250,300,400 R0478000
44*	Harn Wtr Press Switch, Univ. Cntrl	All	R0457800	85*	Panel Bottom, Header, In/Out	All R0478100
45*	Harn Man. Reset, RL-Out	All	R0457900	86*	Panel, Top, Header, In/Out	All R0477700
46*	Harn Air Flow Switch	All	R0460400	87*	Heat Exchanger, Complete, Copper	All R0500503,04,05
47	Power Distribution Circuit Board	All	R0458100	87*	Heat Exchanger, Complete, CuNi	All R0500603,04,05
48	Universal Control PI PCB	All	R0458200		Optional	
49	Univ. Control User Interface	All	R0458300	88*	Non Comb Base	250,300,400 R0468803,04,05
50	Cover, Display/Bezel	All	R0458400	89*	Touch-up Paint	All R0335800
51*	Gasket, Display/Bezels	All	R0458500	90*	Temperature Rise Measurement Kit	All R0336000
52	Flame Sense Rod	All	R0458600	91*	Pressure Relief Valve	All R0336100
53	Fusible Link	All	R0012200	92*	High Temp Silicone Sealant	All R0322800
54	Bracket, Fusible Link	All	R0337200	93*	Tailpiece w/ Union Nut (Set of 2)	All R0449000
	Jacket Assy			94*	Sweep Elbow	All SEAQL1001
55	Door w/ Latch	250,300,400	R0458703,04,05	95*	Sidewall Vent Installation Kit	250,300,400 R0467301,02,03
56	Door Latch Assembly w/ Handle	All	R0334900	96*	Category III Vertical Vent Installation Kit	250,300,400 R0484301,02,03
57	Panel, Side, Left	All	R0458800		NOTES:	
58	Panel, Right Side	All	R0458900		1. All hardware sets contain all pieces necessary for assembly, including gaskets.	
59	Panel, Bottom Header, In/Out	All	R0459000		2. Gaskets and hardware are included in all kits that involve the removal of a gasket as part of the procedure to replace a part.	
60	Panel Top, Header, In/Out	All	R0459100		* PARTS NOT SHOWN ON KEY VIEW	
61	Panel, Return Header Side	All	R0459200		** MANIFOLD KIT INCLUDES INSTALLED ORIFICES, BUT DOES NOT INCLUDE GAS VALVE	
62	Panel, Side Support	All	R0459300			
63	Rear Panel	250,300,400	R0459803,04,05			
64	Vent Back Cover	250/300,400	R0459401,02			
65	Top Assy, Split Flue	250,300,400	R0495303,04,05			
66	Front, Support Door	250,300,400	R0459903,04,05			
67	Housing Air Chamber	250,300,400	R0460003,04,05			
68	Cover, Air Chamber	250,300,400	R0460103,04,05			
69	Cover, Manifold	All	R0460200			
70	Grommet Seal 2"	All	R0460300			
71	Air Duct	All	R0460500			

11.3 General Exploded View

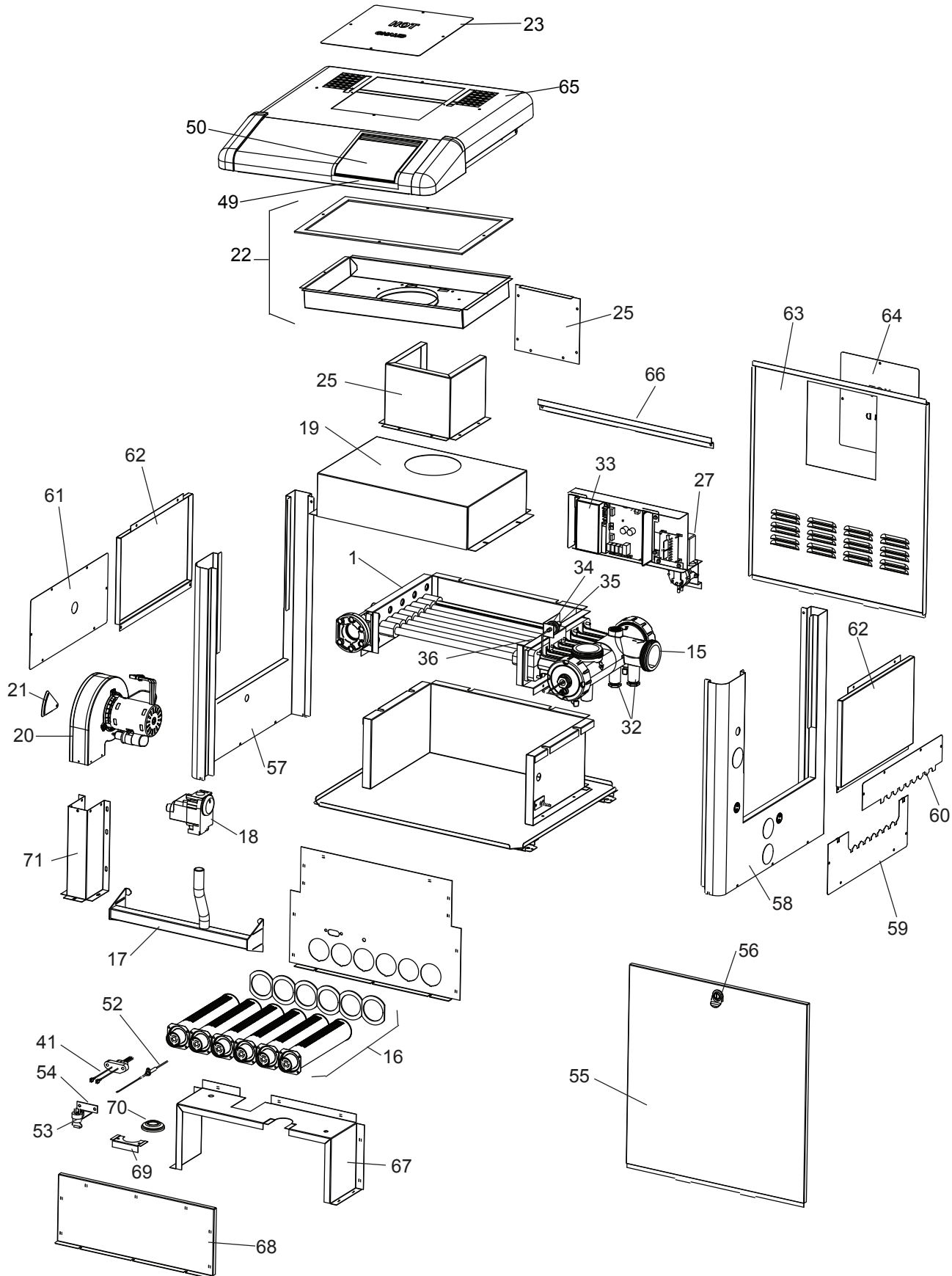

11.4 Detailed Exploded View

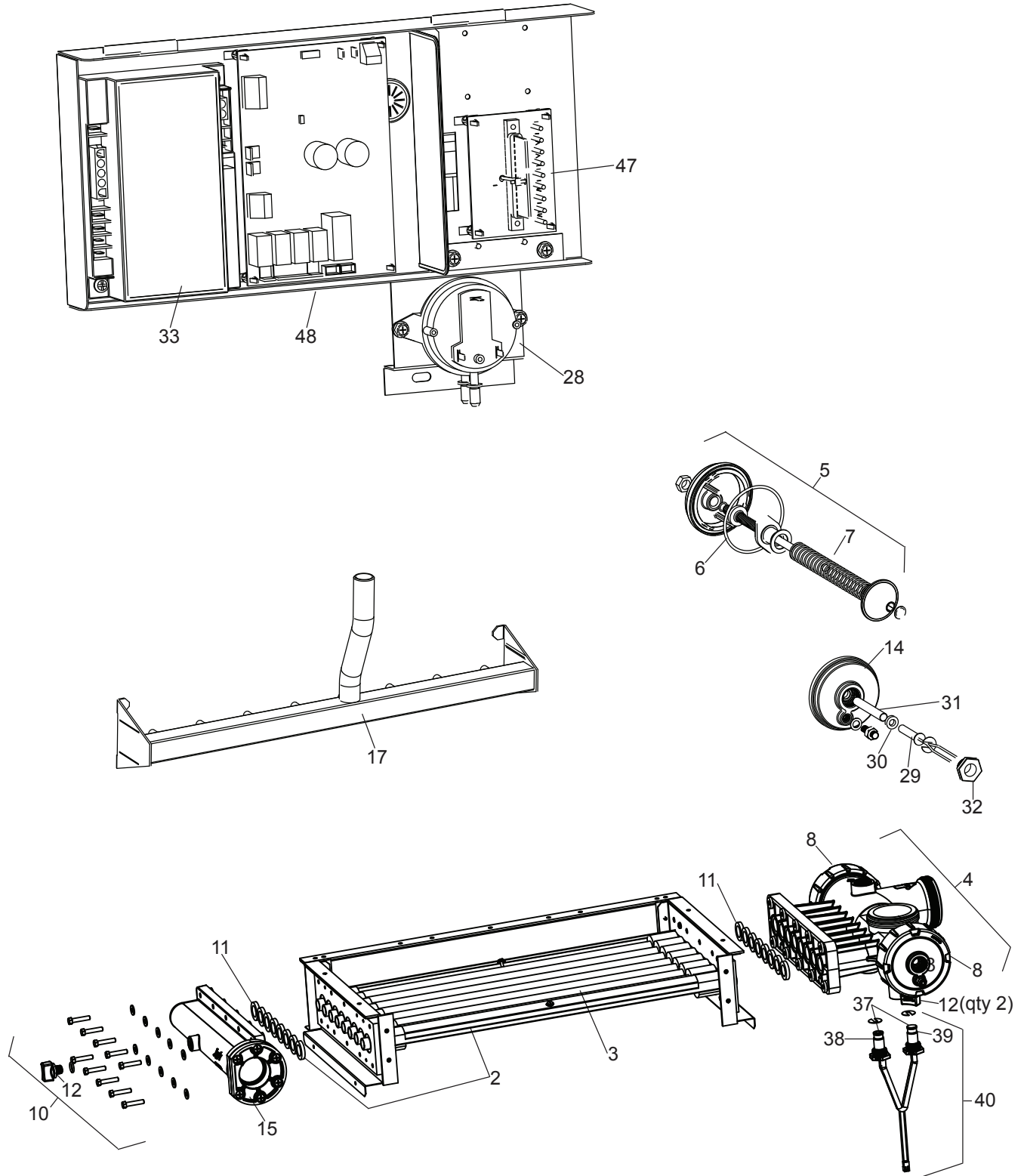

11.5 Exploded View of Heat Exchanger, Bronze

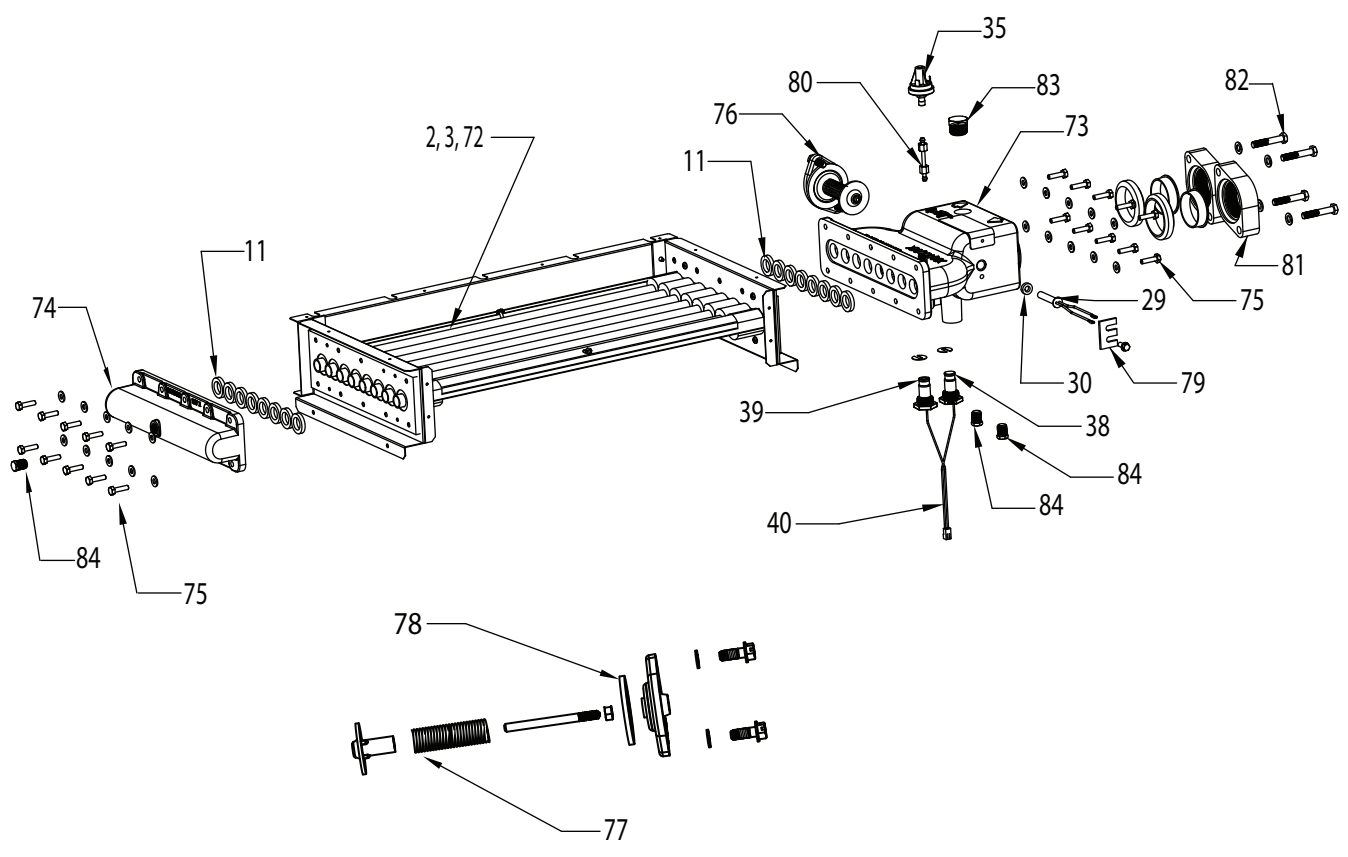

Notes

Notes

Notes

Limited Warranty

Zodiac Pool Systems, Inc. ("Zodiac") warrants all Baracuda®, Jandy®, Nature2® and Polaris® brand products to be free from manufacturing defects in materials and workmanship for a period of one (1) year from the date of retail purchase, with the following exceptions:

1. Jandy heat pumps are warranted for two (2) years. Heat pump compressors and heat exchangers are warranted for five (5) years.
2. Electronic salt water chlorine generators are warranted for three (3) years.
3. In-floor cleaning heads are warranted for the life of the pool on which they were originally installed, if originally installed with Zodiac's in-floor cleaning valves. In-floor cleaning hydraulic valves, UltraFlex® 2 valve housings, and Leaf Trapper™ deck canisters are warranted for three (3) years.
4. Nature2 cartridges, except Spa sticks, CF cartridges, and Spring cartridges, are warranted for six (6) months. Spa sticks and CF cartridges are warranted for four (4) months. Spring cartridges are not warranted. Cense® is not warranted.
5. Baracuda X7 Quattro® and S3 cleaners are warranted for two (2) years.
6. Frames for Polaris ATV®, 280, 360, 380, 480 and 3900S cleaners are warranted for five (5) years.
7. Kontiki cleaners are warranted for ninety (90) days.
8. Pool cleaner wear-and-tear items including, but not limited to, bags, tires, sweep hoses, sweep hose scrubbers, surface disks, flaps, shoes, belts, rollers, scrubbers, and footpads, are not warranted.
9. Refrigerant and other expendables are not warranted.
10. Replacement products, or parts, provided at no charge are warranted only until the original finished good's warranty has expired. Purchased replacement parts are warranted for ninety (90) days from the date of retail purchase.

This warranty applies only to products purchased and utilized in the 50 United States and Canada, is limited to the first retail purchaser, is not transferable, and does not apply to products that have been moved from their original installation sites. The liability of Zodiac shall not exceed the replacement of the defective product or its parts, and does not include transportation costs, costs for labor to service or repair the defective product, or any items or materials required to make the repair including, but not limited to, refrigerant and other expendables. Zodiac is not responsible for charges or delays incurred when a servicer is unable to perform service due to lock outs, animals, intolerable pool or spa water temperature when entry into pool or spa is required to perform service, service refusals, etc. No reimbursements will be made for loss and/or usage of water, fuel or other resources resulting from product defect. A third party service provider may charge the end-user customer for parts and/or labor required to resolve any issue not covered under warranty, such as improper installation. Zodiac is not responsible for these charges. Product discoloration, or any other cosmetic or superficial damage or deterioration, regardless of its cause, is not covered by this warranty. This warranty does not cover failures, defects, malfunctions or complaints resulting from any of the following:

1. Failure to properly install, operate or maintain the product in accordance with Zodiac's published installation, operation and/or maintenance manuals.
2. The workmanship of any installer of the product.
3. Use of non-factory authorized parts or accessories in conjunction with the product(s).
4. Product modifications or adjustments that are not in accordance with Zodiac's published installation, operation and/or maintenance manuals.
5. Not maintaining proper pool and/or spa chemical balance [pH levels between 7.2 and 7.8, with ideal range being between 7.4 and 7.6; Total Alkalinity (TA) between 80 to 120 ppm; Total Dissolved Solids (TDS) less than 2000, not including salt ppm].
6. Corrosion, erosion, scaling, calcification or other conditions caused by water hardness, chemical imbalance, or lack of product maintenance.
7. Chemical contamination of combustion air; or improper use of pool/spa chemicals, such as introducing chemicals upstream of the heater or cleaner hose, or through the skimmer; or use of copper-based algaecides in conjunction with Nature2 products.
8. Abuse, damage during transit or installation, mis-handling, tampering, vandalism, alterations, accidents, fires, floods, storms, earthquakes, power surges, lightning, pets or other animals, insects and/or their hives or nests, negligence, or acts of God.
9. Not grounding and/or bonding as specified, mis-wiring, loose wiring, cut or kinked wires, loose cable connections, incorrect wire runs, incorrect breaker size, breaker(s) in "off" position, improper wire gauge, moisture in electrical conduit, improper electrical supply, dead batteries, incorrect plumbing, inadequate size of pipe and/or fittings, cross-threading, over-tightening, under-tightening, glue drips or residue, improperly secured covers, improper valve placement or usage, unsynchronized valve actuators, valve actuators in "off" position, improper gas pipe sizing, lack of fuel, inadequate heater vent pipe sizing, programming errors, or removal of in-line filter screens from pool cleaners.
10. Freezing, corrosion, cracking, overheating, warping, flooding, moisture intrusion or any other condition caused by or related to weather, climate, improper winterization, improper equipment placement, inadequate ventilation, inadequate water circulation, roof run-off, sprinklers, irrigation systems, or lights or other products on or near the pool/spa or pool/spa equipment pad.
11. Operating the product at water flow rates below minimum, or above maximum, specifications. Operating any product or piece of equipment including, but not limited to, pumps, with insufficient quantities of water.
12. Improper equipment sizing, or product mis-applications including, but not limited to, unsuitable application of a pool cleaner, or use of residential products on commercial applications.
13. Dirty, clogged, blocked, covered or obstructed plumbing, cleaner parts, chlorine generator cells or sensors, pump strainer baskets, pump impellers, heater orifices (including blockage by spider webs), heater grills, doors, flue boxes, flue vents or flue collectors, filter elements, or filter breather tubes.
14. Collateral damage caused by failure of any component including O-rings, pump strainer baskets, DE grids, sand filter laterals, or cartridge elements.

This is the only warranty given by Zodiac. No one is authorized to make any other warranties on behalf of Zodiac. IMPLIED WARRANTIES, INCLUDING THE IMPLIED WARRANTY OF MERCHANTABILITY AND THE IMPLIED WARRANTY OF FITNESS FOR A PARTICULAR PURPOSE, ARE LIMITED TO THE EXPRESS WARRANTIES LISTED ABOVE. Some states and/or provinces do not allow limitations on how long an implied warranty lasts, so the above limitation may not apply to you. Zodiac expressly disclaims and excludes any liability for consequential, incidental, indirect, or punitive damages for breach of any expressed or implied warranty. In no event shall Zodiac be liable for incidental or consequential damages of any nature, including damage to vinyl liners, plaster, aggregate-based pool surfaces, tile, stone, coping, fixtures, skimmers or skimmer covers, plumbing, drains, equipment covers or shelters, landscaping, animals, plants, or dwellings. Some states and/or provinces do not allow the exclusion or limitation of incidental or consequential damages, so the above limitation may not apply to you. Certain vinyl liner patterns are particularly susceptible to rapid surface wear or pattern removal caused by objects coming into contact with the vinyl surface, including pool brushes, pool toys, floats, fountains, chlorine dispensers, and automatic pool cleaners. Some vinyl liner patterns can be seriously scratched or abraded by rubbing the surface with a pool brush. Ink from the pattern can also rub off during the installation process or when it comes into contact with objects in the pool. Zodiac is not responsible for, and this warranty does not cover, pattern removal, cuts, abrasions or markings on vinyl liners.

This warranty gives you specific legal rights. You may also have other rights that vary by state and/or province. For warranty consideration, contact the original dealer and provide the following information: proof of purchase, model number, serial number, date of retail purchase, and date of installation. The dealer will contact the factory to obtain instructions regarding the claim and to determine the location of the nearest independent service company. If the dealer is not available, you can locate an independent service company in your area by visiting www.baracuda.com, www.jandy.com, or www.polarispool.com, or by emailing our Technical Support department at techsupport.vista@zmp-zodiac.com, or by calling our Technical Support department at 800-822-7933. In Canada, call 888-647-4004. All returned parts must have a Returned Material Authorization number to be evaluated under the terms of this warranty.



Jandy®

Zodiac Pool Systems, Inc.
6000 Condor Drive, Moorpark, CA, USA 93021 • 800.822.7933 FAX 877.327.1403

Litho in USA © Zodiac Pool Systems, Inc. 0909